

Plasmatronics PL Series

Advanced Solar Charge Controller

Reference Manual



Contents

0.1 Introduction.....	4
0.2 Additional Installation Notes	4
0.3 Features.....	5
0.4 Thermal Protection	5
1.0 BATV Menu	6
The Regulation Cycle	6
1.1 BOST (Boost)	6
Returning to Boost state	6
1.2 Equalise (optional)	7
1.3 ABSB (Absorption)	7
1.4 FLOT (Float)	7
2.0 CHRG Menu.....	8
CHRG	8
CINT	8
CEXT	8
Generator Control	8
GSET	8
GMOD	9
GEXD (Generator Exercise).....	10
GDEL (Generator changeover delay)	10
Generator Example	10
3.0 LOAD Menu	12
LOAD	12
LINT	12
LEXT	12
Low Battery Disconnect (LSET, LOFF, LON, LDEL).....	12
4.0 IN Menu	13
IN	13
IN/INT	13
IN/EXT	13
5.0 OUT Menu	13
OUT.....	13
OUT/INT	13
OUT/EXT	13
6.0 DATA Menu (Retrieving Performance Data)	14
6.1 & 6.2 VMAX & VMIN	14
6.3 FTIM (Float time Display)	14
6.4 SOC (State of Charge Display)	14

6.5 TEMP (External Battery Temperature Sensor Display)	15
Setting Lockout	15
6.6 SOLV (Solar Voltage Display)	16
6.7 HIST (History display)	16
7.0 SET menu	17
7.1 TIME	17
7.2 VOLT	17
7.3 PROG (Adjusting Regulation Settings)	17
Program Function Table (Generic Programs)	17
Program Description	17
Settings Used in Programs 0-3	18
Settings for Program 4	18
7.4 REG menu (Customising Regulation Settings)	19
7.4.1 HYST (Hysteresis Value).....	19
7.4.2 Charge Current Limit	20
7.4.3 TCMP (Temperature compensation)	20
Connecting a Temperature Sensor	21
7.5 MODE Menu (Adjusting Configuration Settings)	22
7.5.1 & 7.5.2 LSET & GSET	22
Shunt Control.....	24
7.5.3 BSET: Configuring B- Sense Input.....	24
7.5.4 BAT2 - Second battery control	26
7.5.5 PWM and Slow Switching	27
7.5.6 BCAP	28
7.5.7 ALRM	28
7.5.8 RSET	28
7.6 EVNT Menu (Event Control)	29
Using the Event Controller	29
Examples:	33
A.0 Appendices	34
A.1 'Catch diode' protection	34
A.2 Accessories	34
A.3 Specifications on PL20, 40, 60	35
A.3.1 Block Diagram of PL20/40 Hardware	36
A.3.2 Block Diagram of PL60 Hardware	36
A.4 Thermal derating	37
A.5 Mechanical Information	38
Programs 0-3 Menu System	40
Program 4 Menu System (for custom settings)	41

0.1 Introduction

Please read the User Guide before reading this manual.

In most cases, the User Guide provides all the information needed for effective installation of the PL, and there is no need for the user to read this Reference Manual.

However, in some cases, users with a good understanding of power regulation may wish to customise individual settings or adjust some of the PL's advanced features. This manual describes the procedures for making these adjustments.

Please note that this manual assumes more technical knowledge than the User Guide.

If you are in any doubt, it is recommended you do not adjust the advanced settings described in this manual. Incorrect adjustment may reduce the effectiveness of your PL and could damage your battery.

All voltage values used in this manual assume a 12V system. Scale voltages for other system voltages (e.g. 24V system = voltages x 2, 48V system = voltages x 4)

0.2 Additional Installation Notes

Ensure that you have followed the installation instructions on pages 3-5 of the User Guide. The PL can be used for system voltages of up to 48V. It is safe to connect the power before setting the system voltage, even with a 48 volt battery.

Always mount the PL vertically with clear airflow around the fins. In hot conditions, do not put the PL in a sealed enclosure, as this will restrict the airflow around it. Do not install the PL in direct sunlight in hot conditions - the heatsink may reach over 70°C in some environments.

The PL is specified for up to 50°C ambient temperature. If the LCD display reaches 60°C it will darken and may become unreadable, however it will return to normal when it cools down.

0.3 Features

The PL series of solar controllers are exceptionally versatile. They give the user unparalleled capability to adjust the function of the controller and to monitor the performance of the energy system.

To cater for both non technical and technical users, the PL has four preset programs which can be used without needing to understand the details of its operation. For those with a good understanding of power regulation, there is another program, which allows all the settings to be adjusted if required.

Once the program has been selected, it is possible to disable any further adjustment. This prevents unauthorised adjustment of settings.

Although the PL is primarily a device to control the charging of batteries from solar electric (photovoltaic) panels, it can also be used with other energy sources such as wind, microhydro and fuel driven generators.

The PL can support a variety of regulation methods. It supports slow speed switching and fixed frequency pulse width modulation (PWM) control in series and shunt modes.

There is provision for a temperature sensor to be attached. There is an input for measuring external voltages. A serial interface is provided for accessories including remote shunt adapters (PLS2) and an RS232 adapter to communicate with a computer/modem (PLI).

The PLI allows remote monitoring and adjustment. Custom settings can be stored on a computer and uploaded into the PL controller. Data from the PL can be downloaded into the computer and displayed easily.

Low battery voltage load disconnection is provided, as are an alarm, facility to control the charging of a second battery bank, control for a back up generator and an event controller which can be used to control lights, pumping, waste energy use and other timer functions. A temperature sensor can be added to correct the regulation voltages for battery temperature.

The PL controller can have external current shunts attached and control larger systems through external switch blocks or relays.

0.4 Thermal Protection

The PL has a temperature sensor on the circuit board. The function of this sensor is to tell the PL how hot it's own circuit board is so that it can reduce the charge current (the major heating source) in order to protect against overheating. It's virtually impossible for a correctly installed PL in good order to overheat.

1.0 BATV Menu

The BATV screen, shown at power-up, gives the real-time battery voltage.

Note: On recent units there is a software version number shown on the display for approximately 1 sec each time the regulator is turned on - this is not a voltage.

Long push on BATV screen will display current regulation cycle state.

The Battery Charge Cycle

The PL's sophisticated regulation system is designed to keep the battery fully charged without overcharging it.

To achieve this, it uses a charge control process with three main states. These states are Boost, Absorption and Float. The PL also uses a fourth state from time to time, called the Equalisation state (See fig 1B.)

1.1 BOST (Boost)

In the boost stage, all the charge current available is used to charge the battery. As the battery charges, its voltage rises. When the voltage reaches the boost maximum voltage (BMAX) and remains there for 3 minutes, the controller will automatically advance to the absorption stage.

Returning to Boost state

To get this charge cycle to repeat, the PL must return to the boost state. There are three ways that it can do this.

Fig. 1B - The Battery Charge Cycle

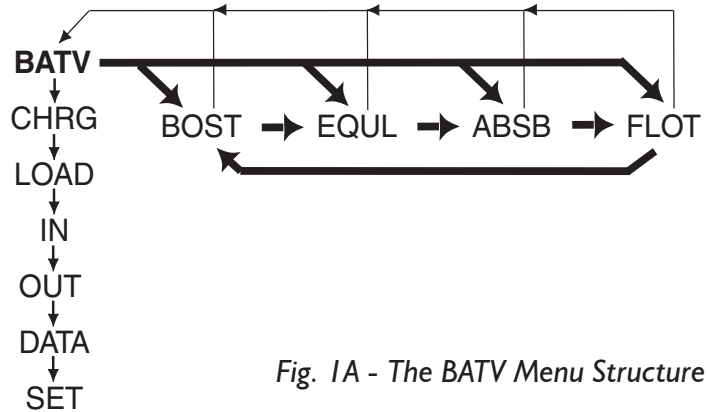
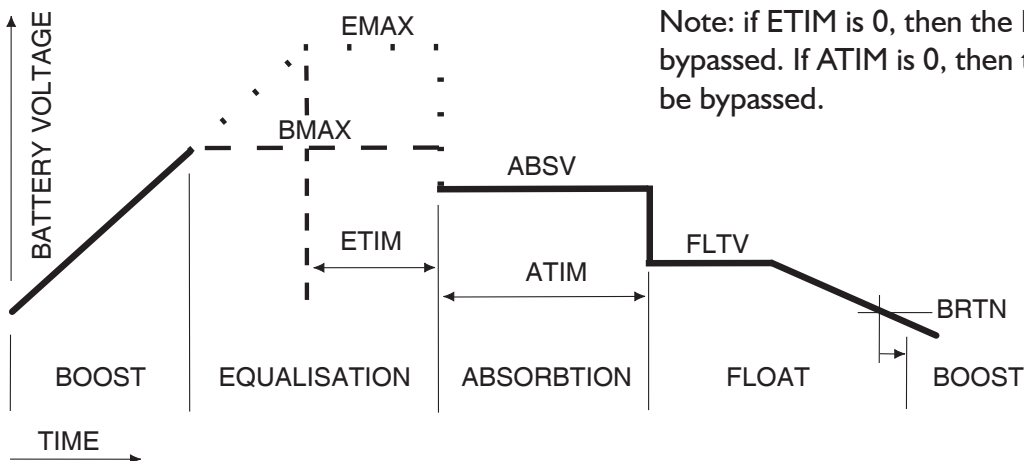

Fig. 1A - The BATV Menu Structure

a. Low Battery Voltage

If the battery voltage falls below the boost return voltage BRTN for more than 10 minutes, then the PL will switch back into the boost state. The delay is necessary to prevent large short term loads causing unnecessary returns to Boost state.

b. Programmed boost cycles (optional)

The PL will automatically do a boost cycle after a set number of days (BFRQ), regardless of battery voltage.

c. Manual boost

The user can manually set the PL into the boost state (or any of the regulation states).

To manually advance to the next state, do a long push on BATV. This will show the current regulator state. (BOST=Boost, EQUL=Equalise, ABSB=Absorption, or FLOT=Float). A long-push on that state will manually advance the PL into the next state. Or, to return to the BATV screen without changing the state, do a short push.

Note: if ETIM is 0, then the Equalise state will be bypassed. If ATIM is 0, then the Absorb state will be bypassed.

On the BOST and FLOT displays, the battery voltage is shown. On the EQUL and ABSB displays, the time on the equalisation or absorption timer is displayed. When this time gets up to the set time (ETIM or ATIM) the PL will advance to the next state. Remember that the timers will stop if the voltage falls below the relevant set point.

1.2 Equalise (optional)

Many battery manufacturers recommend that the battery bank be given an overcharge occasionally. This is designed to equalise the voltages and specific gravities of all the cells in the bank by bringing them all up to full charge and to stir up the electrolyte in liquid cells to reduce stratification.

The PL supports an automatic programmed equalisation. This state allows the battery voltage to rise until it gets to the equalisation voltage EMAX and then remain at this voltage for the set equalisation time ETIM. This equalisation is done every EFRQ days. (Typically 30-60 days). Equalisation will begin at 9am on the appropriate day. If ETIM is 0, then equalisation will not occur.

To prevent the controller being trapped in equalise mode for a long time because there is inadequate charge current to reach the equalise voltage, the PL terminates equalise after 4 days

1.3 ABSB (Absorption)

In this state, the PL tries to keep the battery voltage constant while the last part of the battery charging occurs. This prevents excessive gassing which occurs at high cell voltages. The PL will keep the battery voltage at the absorption voltage ABSV until it has been at this voltage for the absorption time ATIM. If there is a cloudy period and there is insufficient charge current to keep the voltage up to ABSV, then the absorption timer will stop and resume when the voltage comes back up to ABSV. When the absorption time is finished, the PL advances to the Float state.

1.4 FLOT (Float)

In this state, the battery has been fully charged. The charge current is now used to keep the battery voltage at a level which maintains full charge. This voltage (FLTV) should be below the gassing voltage to avoid excessive electrolyte loss. If charge is drawn from the battery, the PL will allow charging to resume until the battery returns to FLTV.

2.0 CHRG Menu

CHRG

The CHRG screen gives the real-time total charging current (Amps). This total is the sum of solar charge current (CINT) and any external charge current (CEXT) measured using an optional shunt and PLS2.

CINT

From the charge screen, a long push displays CINT (Charge Internal). This is the real-time solar charging current in amps.

CEXT

From the CINT screen, a short push displays CEXT (Charge External). This is the real-time external charging current measured using an optional shunt and PLS2.

Generator Control

The PL has a comprehensive generator controller built in. It works in a similar way to Low Battery Disconnect, using an internal function. It is designed to give a run or stop signal to an electronic start generator. It does not handle the actual generator start-up sequence - this should be done by the generator itself.

GSET

In the GSET screen, a long push will manually change the state of the generator output. The GEN indicator at the bottom of the screen is visible when the generator function wants the generator to be running.

Fig. 2A - Generator Control Menus (PROG=4 only)

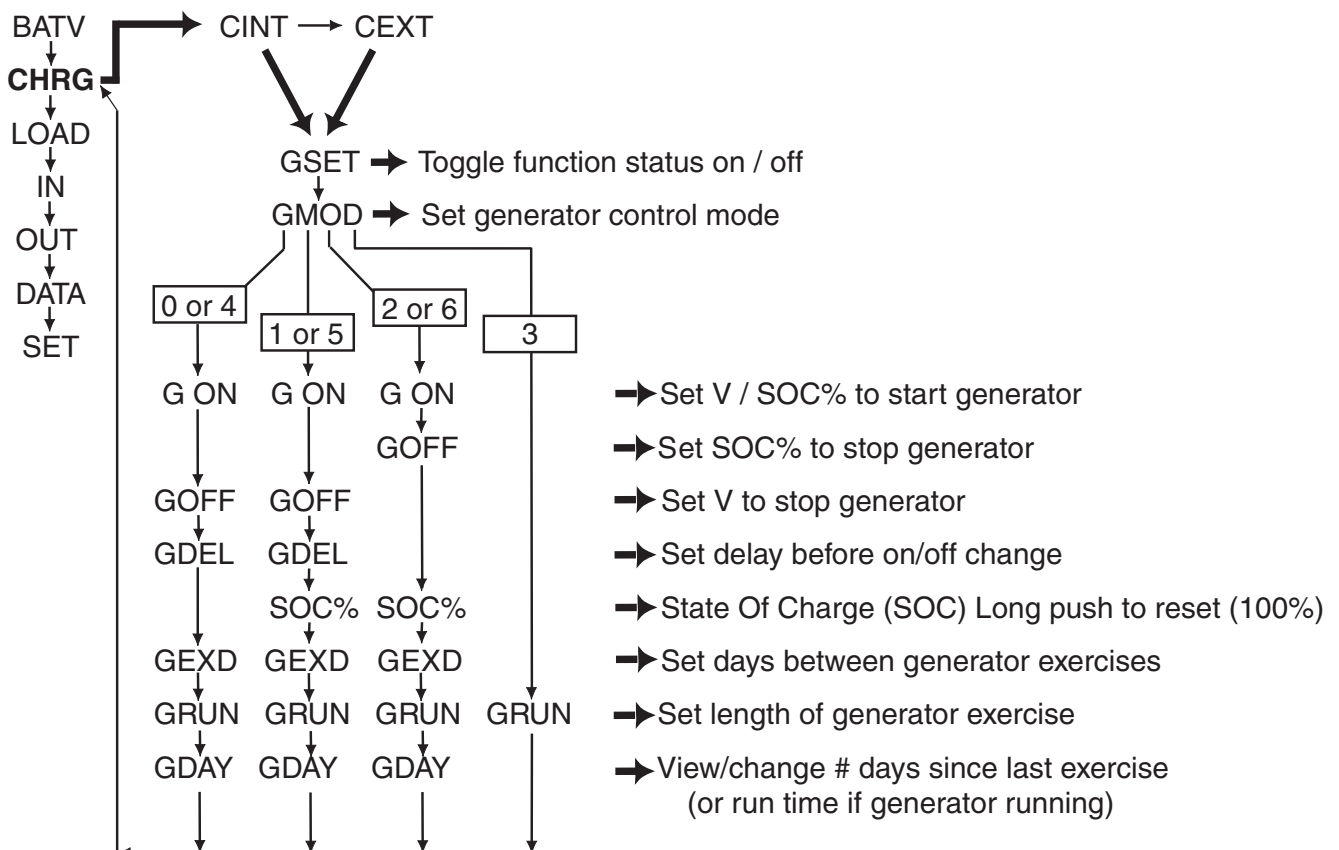

GMOD

The generator can operate in four different modes. The generator mode is selected in the GMOD screen and can be 0-6.

Quiet time: In modes 0,1 & 2, the generator is not allowed to operate from 9pm until 9am so as to enforce a 'quiet time'.

Modes 4-6 are the same as modes 0-2 except that there is no quiet time.

Note - do not confuse the GSET described in Figure 2A with the screen of the same name described in Section 7.5.2.

Mode#	Description
0.	Turn on when battery voltage falls to G ON for GDEL minutes. Turn off when the voltage rises to GOFF for GDEL minutes. Quiet time applies.
1.	Turn on when the State of Charge (SOC%) falls to G ON % of the battery capacity. Turn off when the voltage rises to GOFF for GDEL minutes. Quiet time applies.
2.	Turn on when SOC % falls to G ON%. Turn off when SOC% rises to GOFF%. (GOFF% can be set to greater than 100% to allow some overcharge.) Quiet time applies.
3.	Manual start. When started (in the GSET screen) the generator will run for GRUN hours.
4.	No quiet time. Turn on when battery voltage falls to G ON for GDEL minutes. Turn off when the voltage rises to GOFF for GDEL minutes.
5.	No quiet time. Turn on when the State of Charge (SOC%) falls to G ON % of the battery capacity. Turn off when the voltage rises to GOFF for GDEL minutes.
6.	No quiet time. Turn on when SOC % falls to G ON%. Turn off when SOC% rises to GOFF%. (GOFF% can be set to greater than 100% to allow some overcharge.)



GMOD:	Quiet Time			M*	No Quiet Time			Name	Description	Range
	0	1	2	3	4	5	6			
	•				•			GON	Set V to start generator	10-12.5V
		•	•			•	•	GON	Set SOC% to start generator	0-99%
	•	•			•	•		GOFF	Set V to stop generator	11.0-16.5V
			•				•	GOFF	Set SOC% to stop generator	1-125%
	•	•			•	•		GDEL	Set delay before on/off change	1-15 min
		•	•			•	•	SOC%	Current SOC% Long push to reset to 100%	0-127%
	•	•	•		•	•	•	GEXD	Set days between generator exercise	2-60 days
	•	•	•	•	•	•	•	GRUN	Set length of generator exercise	0-4.0 hrs
	•	•	•		•	•	•	GDAY	View/change # of days since last exercise	2-60 days

• = Active Parameter for relevant generator mode (GMOD)

*M = Manual

GMOD = GMOD Settings

GEXD (Generator Exercise)

To prevent the generator from seizing up, it is good practice to exercise the generator periodically. The PL supports this with an automatic generator exercise function, which will turn on every GEXD days. The number of days since the last exercise is shown on the GDAY screen. The generator will run for GRUN hours. When running, the elapsed time is shown on the GTIM screen. Both GDAY and GTIM can be adjusted.

Note:

1. *There is no generator exercise when GMOD = 3 (manual start).*
2. *GSET toggle does not work during generator exercise*
3. *A small amount of overcharge will occur if battery is already fully charged. Use a low GRUN value if this is of concern.*

GDEL (Generator changeover delay)

A programmable delay (in minutes) is used to prevent any large transient loads from triggering a generator change of state (on/off). Default programs are 10 min.

Generator Example

The generic programs (PROG=0-3) use voltage driven generator control (GMOD=0). See “settings used in Programs 0-3” for on-off voltages etc.

If you want something different, eg SOC%-triggered generator on, voltage-triggered generator off, and no quiet time, you would set up the regulator as follows:

PROG = 4	Allows changing of generator functions etc
GMOD = 5	SOC % ON, Voltage OFF, no quiet time
CHRG menu :	Set GON, GOFF, GDEL, GEXD, GRUN as required
SET/REG :	Check these settings are correct for your battery type
Mode menu : LSET = 2 or GSET = 2	LSET if using LOAD - terminal for relay GSET if using 'G' terminal for relay

PL20/40 Generator start relay wiring

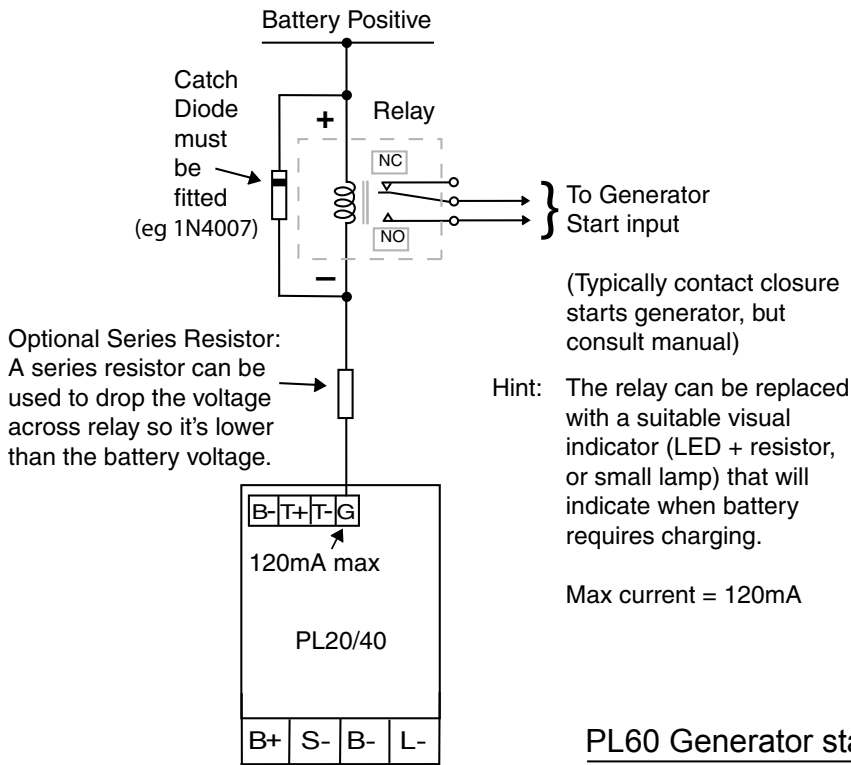

Fig. 2B - PL20/40 Generator start relay wiring



PL60 Generator start relay wiring

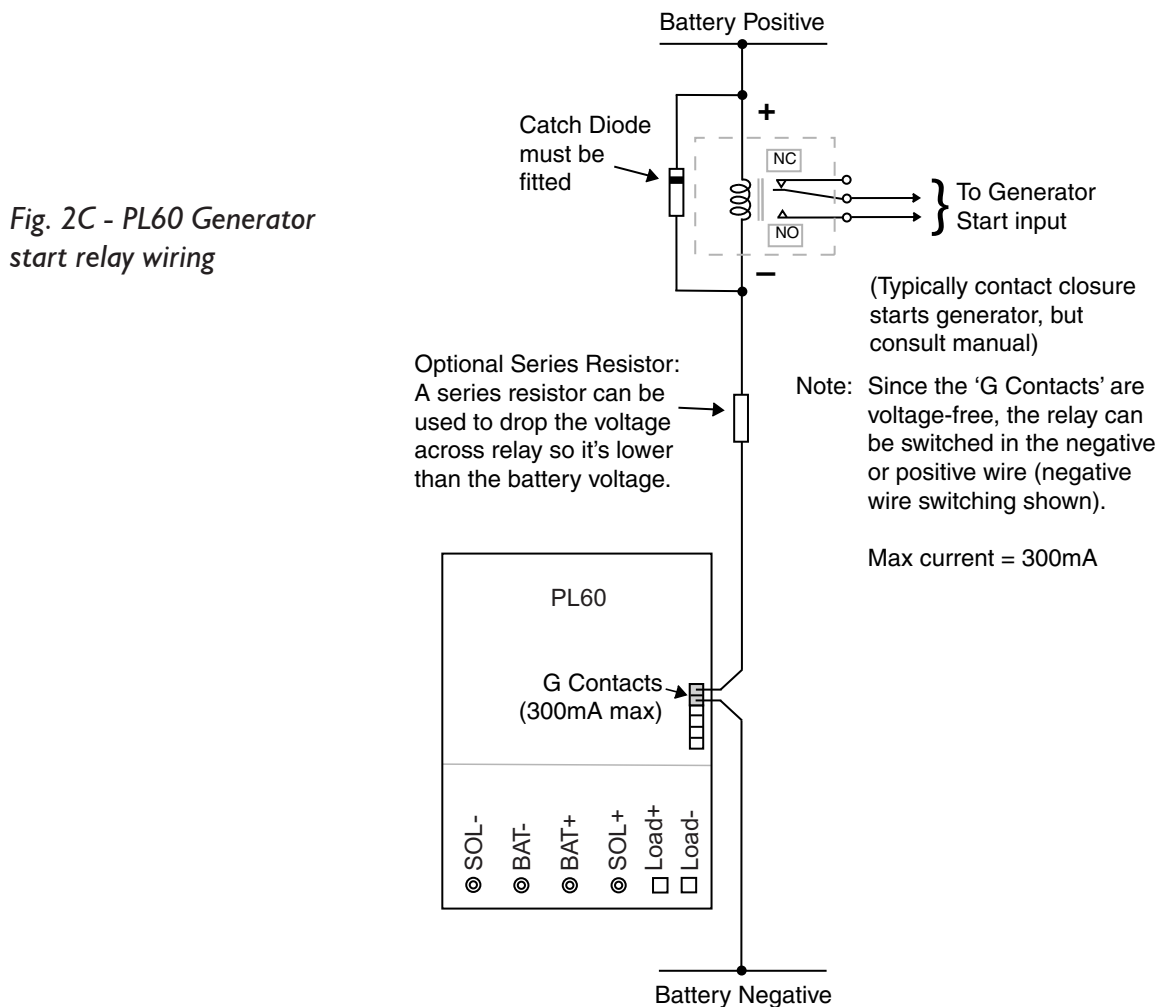

Fig. 2C - PL60 Generator start relay wiring

3.0 LOAD Menu

LOAD

The LOAD screen gives real-time total load current (in Amps). This total is the sum of load current used by equipment connected to the LOAD- terminal and any external load current measured using an optional shunt and PLS2.

LINT

From the LOAD screen, a long push displays LINT (Load Internal). This is the real-time load current used by equipment connected to the regulator's LOAD- terminal.

LEXT

From the LINT screen, a short push displays LEXT (Load External). This is the real-time external load current measured using an optional shunt and PLS2.

Low Battery Disconnect (LSET, LOFF, LON, LDEL)

To prevent battery damage due to over-discharge, the PL has an internal function which can be set to turn off either the LOAD- terminal or the "G" terminal if the battery voltage falls too low. (This feature is also sometimes referred to as "Load Control").

If correctly configured, equipment connected to the battery (the "load") will be turned off when the LOAD- or "G" terminal is turned off. Once turned off, the load will not be reconnected until the voltage rises enough to indicate some recharge has taken place.

Name	Description	Range
LOFF	Set voltage at which load disconnects	10.0-12.5 V
LON	Set voltage at which load reconnects	11.0-16.0 V
LDEL	Set delay before switching on/off	0-15 min

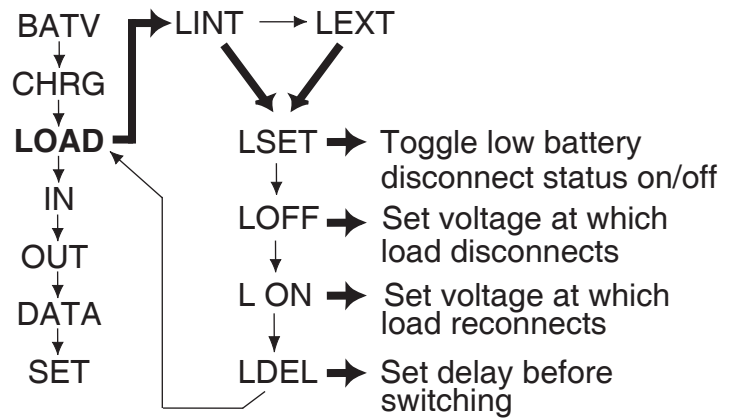

Fig. 3A - LOAD Menu

This feature is optional, and can be disabled either by connecting the user load directly to the battery, or by setting the parameters to ensure the low battery disconnect function never turns on.

The LOAD indicator at the bottom of the screen is visible when the low battery disconnect function wants to disconnect the load. (Note that other settings can override the function, so the LOAD indicator does not necessarily mean that the power actually has been disconnected from the load.)

The Low Battery Disconnect function can also be toggled manually by a long push when in LSET menu (see Figure 3A).

The low battery disconnect function can be set to use the LOAD- terminal, or the G (General Purpose Output) terminal to disconnect the load. Its operation can also be reversed, i.e. it can turn on the terminal when the function decides the load should be disconnected. This can then be used as a low battery alarm or to drive a relay to turn off other loads.

DO NOT CONNECT AN INVERTER OR ANOTHER BATTERY TO THE LOAD-TERMINAL. This terminal is rated at 20A on the PL20, 7A on the PL40 and 30A on the PL60. Most inverters draw larger currents than this and have their own low battery cut off circuitry anyway.

4.0 IN Menu

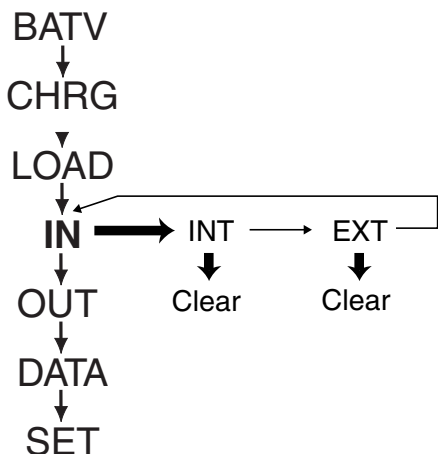

Fig. 4A - IN Menu

IN

The IN screen gives a running total of Amp hours (Ah), or energy, that has been input during the day (since midnight). This total is the sum of Solar Ah collected and any external Ah input that was measured using an optional shunt and PLS2.

IN/INT

From the IN screen, a long push displays INT (Internal Ah IN). This is the running total of Ah collected from the solar over the day (since midnight). A long push will clear the INT running total.

IN/EXT

From the INT screen, a short push displays EXT (External Ah IN). This is the running total of external Ah input and measured using an optional shunt and PLS2. A long push will clear the EXT running total.

5.0 OUT Menu

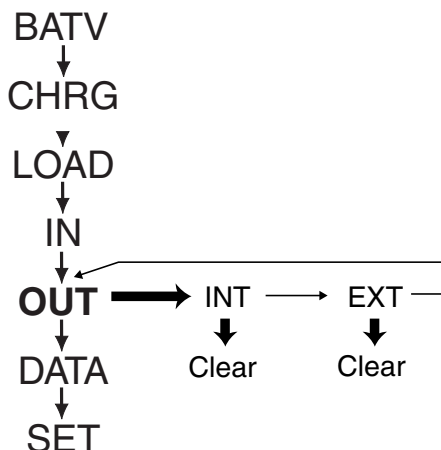

Fig. 5A - OUT Menu

OUT

The OUT screen gives a running total of Amp hours (Ah), or energy, that has been used during the day (since midnight). This total is the sum of Ah used by equipment connected to the LOAD terminal and any external Ah measured using an optional shunt and PLS2.

OUT/INT

From the OUT screen, a long push displays INT (Internal Ah OUT). This is the running total of Ah used by equipment connected to the regulator's LOAD- terminal. A long push will clear the INT running total.

OUT/EXT

From the INT screen, a short push displays EXT (External Ah OUT). This is the running total of external Ah used and measured using an optional shunt and PLS2. A long push will clear the EXT running total.

6.0 DATA Menu (Retrieving Performance Data)

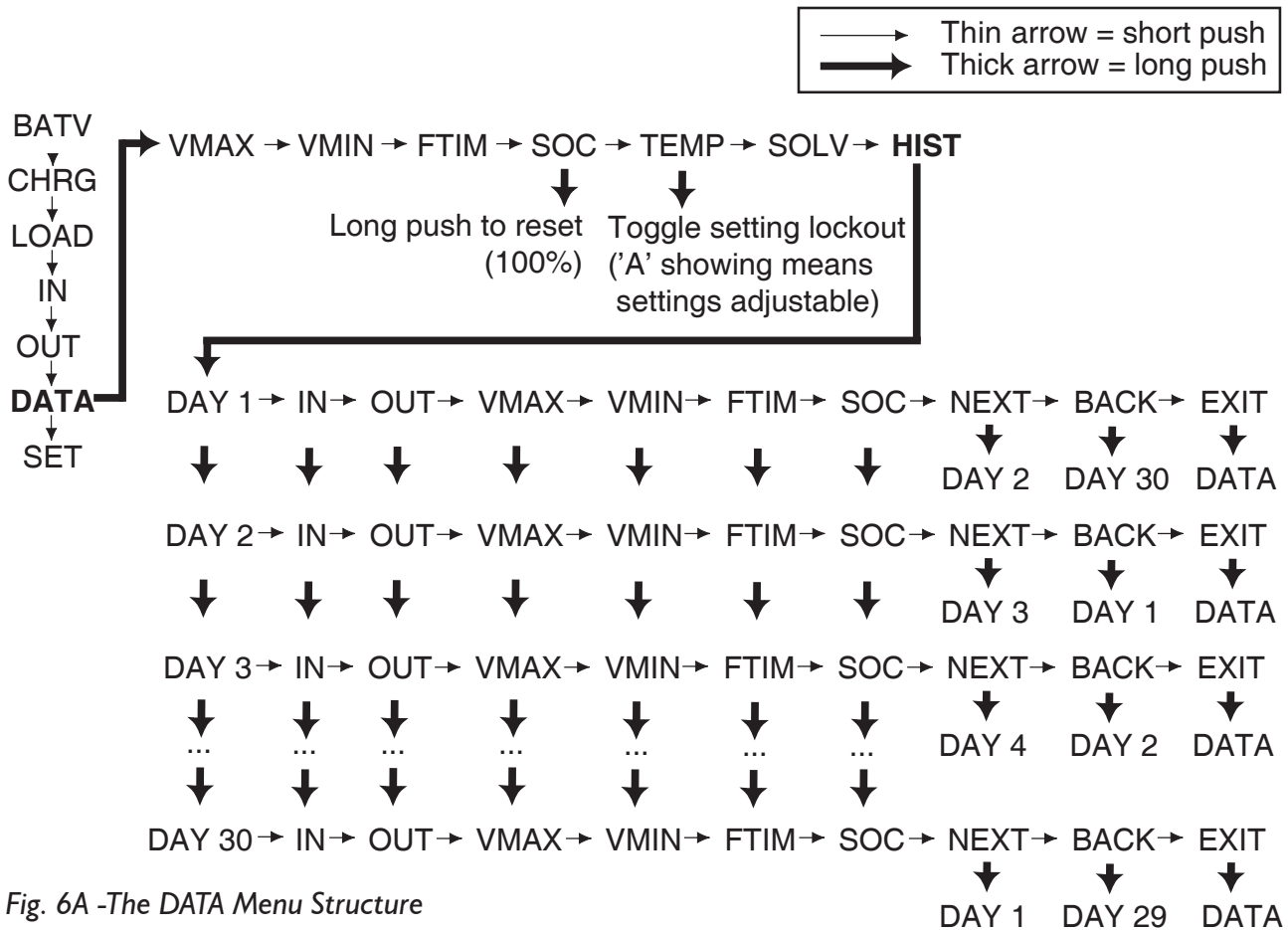

Fig. 6A -The DATA Menu Structure

A long-push on DATA shows performance information for the current day.

The screens in the DATA menu have the following meanings:

VMAX	maximum battery voltage since midnight.
VMIN	minimum battery voltage since midnight.
FTIM	time of day the regulator entered the Float state.
SOC	estimated state of charge of the battery based on the amp hours in and the amp hours out. A very rough 'fuel gauge' -see below for further details.
TEMP	temperature being sensed by the external temperature sensor (if attached).
SOLV	solar panel voltage (open circuit)
HIST	entry point for history data.

At midnight, VMAX, VMIN, FTIM, SOC, IN and OUT are stored in the history data and cleared from the current day readings.

6.1 & 6.2 VMAX and VMIN

VMAX and VMIN respond very slowly to changes in battery voltage. This allows them to ignore short term voltage fluctuations. (Warning: at reset or initial start up, they can take up to 40 minutes to reach the correct value.)

6.3 FTIM (Float time Display)

FTIM indicates the time of day that the regulator changed from the ABSB (Absorption) state to the FLOT (Float) state.

Note: This time will only be recorded if the regulator has done a complete charge cycle, ie.

Boost → Equalise → Absorption → Float
 (if selected)

6.4 SOC (State of Charge Display)

SOC (State Of Charge) should be read as a percentage estimate of how full the battery is.

The estimate is based on the amp hour balance counter. This counter keeps a running balance of amp hours in vs amp hours out. The SOC display shows this balance as a percentage of the battery size. Note that all system currents must be monitored by the regulator and the battery capacity must be entered by the installer with the BCAP setting before SOC will be meaningful.

$$\text{SOC (\%)} = \frac{\text{BCAP} + \text{Ah IN} - \text{Ah OUT}}{\text{BCAP}} \times 100$$

Over time, the amp hour balance counter will drift out of line with the real battery state of charge. To realign the counter the PL automatically makes two corrections:

1. When the regulator state changes from Absorb to Float AND the charge duty cycle is less than 25%, SOC is reset to 100%.
2. SOC is capable of reading more than 100%, however as soon as 1Ah of discharge is recorded it will be set back to 100%, thus discarding any surplus amp hours. These amp hours were really put into the battery, but the battery cannot be more than 100% full. The difference is mostly the inherent loss in the battery. The battery is not 100% efficient either.

Note: A long push on the SOC screen will reset the unit to 100%.

The SOC figure should be treated with caution, as there are several reasons that it may be inaccurate:

- The effective capacity of the battery reduces with age. BCAP should be reduced in older batteries to adjust for this.
- When you set up BCAP on installation, you should choose your best guess of the batteries actual capacity when used in the way you intend to use it. For example, if you think the battery will mostly be charged and discharged at around the 100h rate (C/100) you should set the capacity of you battery at the 100h rate from the manufacturer's literature. If you expect the battery to be used at various charge and discharge currents, try to estimate an average. In many systems it is more accurate to use the C/20 rate.
- Battery self discharge and variations in temperature will also cause some inaccuracy.
- The PL does not automatically have knowledge of the whole system. It only knows what you tell it. For SOC to work at all, the PL must be measuring all charge (Ah in) and discharge (Ah out). If the battery can charge or discharge without the PL knowing, SOC will not be meaningful.
- Variations in charge efficiency mean SOC will tend to be a little optimistic.

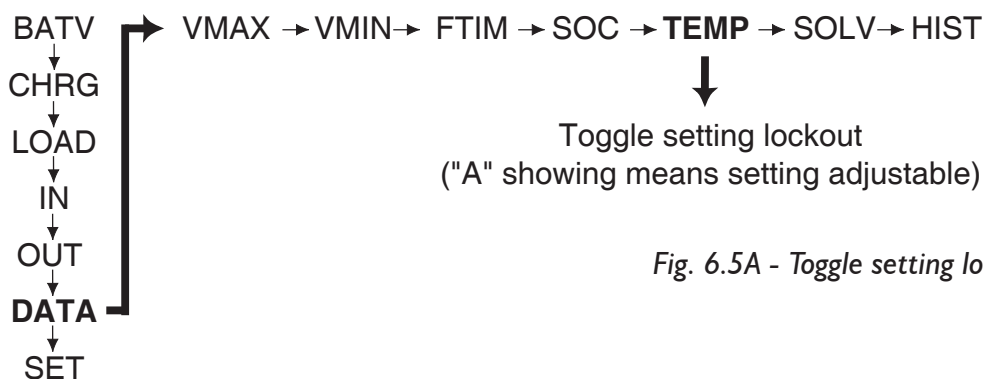

Fig. 6.5A - Toggle setting lockout

6.5 TEMP (External Battery Temperature Sensor Display and Setting Lockout)

In addition to showing the external battery temperature sensor reading (if attached), this menu is also used to adjust Setting Lockout (see figure 6.5A).

Setting Lockout

In some cases it is desirable to restrict the ability to adjust settings, so as to prevent unwanted tampering. Setting lockout is done via the TEMP screen under the DATA menu. (The TEMP screen shows the battery temperature if the optional external temperature sensor is installed, or "0.0" if it's not.)

To disable settings, long push on the TEMP screen, the "A" indicator will disappear. (A useful memory aid is to consider that "A" stands for "Adjust" on this screen.). Note that the same "A" indicator is used on other screens to mean Amps.

To enable adjustment of settings again, long push on the TEMP screen again. If you have successfully enabled settings adjustment, the "A" will reappear while TEMP is showing.

Lockout on early regulators

Note that early models of the PL had a physical link under the cover, which achieved the same purpose. If your PL is an early model and you are still unable to change your settings after following the above procedure, you may need to obtain the settings lockout link. Contact your dealer or Plasmatronics.

If you wish to obtain the link yourself, the Part# is Farnell 510-920 (2mm pitch).

You will need to temporarily disconnect the cable of any accessory installed in the system. The link is installed on the 8 way pin header under the lid of the PL controller (under lower left corner of display).

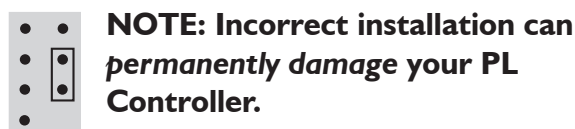

Fig. 6C - Lockout link on early PLs

6.6 SOLV (Solar Voltage Display)

This screen displays the solar panel voltage (open circuit).

Note that the charge current to the battery is turned off while the PL is displaying this screen, but if the view is left on the SOLV screen, the panels will be reconnected when the screen goes to sleep (failsafe).

6.7 HIST (History display)

Six pieces of data are recorded each day. These are IN, OUT, VMAX, VMIN, FTIM and SOC. These records are available for the past 30 days.

At the start of each day record is the DAY screen. This shows which day's data you are looking at (DAY 1 = yesterday, DAY 2 = the day before yesterday, etc.)

For help with navigating through the History, refer to Fig.6A. Note that a short push on the EXIT screen will take you back to the beginning of that day's record.

7.0 SET menu

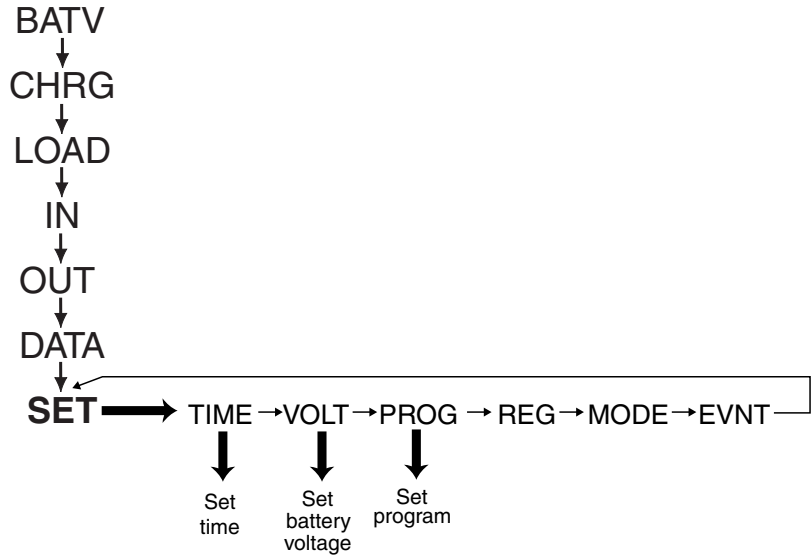

Fig. 7A - The SET Menu

7.1 TIME

A 24hr format is used for system time, with a resolution of 6 minutes (0.1 hours)

NOTE: Removing power to the regulator (ie turning it off) will reset the system time to 0.0hrs (midnight). You will need to re-enter the current time whenever the regulator is restarted. Incorrect system time will result in misleading history data since this is stored at midnight of each day. Generator quiet-time and time-driven event control will also be affected.

7.2 VOLT

Set VOLT to the nominal system voltage for your installation.

This setting determines the regulation and control voltage set-points for your system.

NOTE: Your regulator *will not* be damaged if the voltage is set incorrectly, however you would probably damage your battery (under- or overcharge) if this setting is in error for any length of time.

7.3 PROG (Adjusting Regulation Settings)

The PL comes with a number of preconfigured programs, which are set up for generic batteries. For custom installations, one program (Program 4) allows the user to adjust each setting individually.

If you find you are unable to change your settings, it may be because the “lockout” setting is activated. This setting is designed to prevent unwanted tampering— please see the “Setting Lockout” information in section 6.5.

Program Function Table (Generic Programs)

Program#:	0	1	2	3
Batt Type:	Flooded	Sealed	Flooded	Sealed
LOAD- Term Functions:	No Night Light		Night Light	
	Low Battery Disconnect			

Low Battery Disconnect is enabled for Programs 0-3. Programs 2&3 turn on the LOAD- terminal at night.

Program Description

PROG 0: Use with liquid electrolyte lead acid (ie. flooded) batteries. The LOAD- terminal is set to turn off when the battery is low. (Also known as Low Battery Disconnect)

PROG 1: Use with sealed or gel lead acid batteries. The LOAD- terminal is set to turn off when the battery is low. (Also known as Low Battery Disconnect)

PROG 2: Use with liquid electrolyte lead acid batteries (ie. flooded). The LOAD- terminal is set to turn on at night and can be used for night lighting, but will turn off when the battery is low (Low Battery Disconnect).

PROG 3: Use with sealed gel lead acid batteries. The LOAD- terminal is set to turn on at night and can be used for night lighting, but will turn off when the battery is low (Low Battery Disconnect).

PROG 4: Enables customised adjustment of all settings.

Installation instructions for programs 0-3 are on pages 8-9 of the User Guide.



Settings Used in Programs 0-3

When programs 0-3 are selected, the PL automatically uses the values below in its regulation.

The voltage settings are shown correct for 12V operation. For higher voltages, scale these up (eg. for a 24V system, multiply each voltage figure by 2.)

CHRG	Setting for program number			
	0	1	2	3
Parameter	0	1	2	3
GMOD	0			
G ON (V)	11.5			
G OFF (V)	13.8			
GDEL (Min)	10			
GEXD (Day)	30			
GRUN (Hr)	1.0			

LOAD	Setting for program number			
	0	1	2	3
Parameter	0	1	2	3
LOFF (V)	11.3			
L ON (V)	12.8			
LDEL (Min)	10			

SET/REG	Setting for program number			
	0	1	2	3
Parameter	0	1	2	3
BMAX (V)	15.0	14.2	15.0	14.2
EMAX (V)	16.0	14.0	16.0	14.0
ETIM (Hr)	1.0	0	1.0	0
EFRQ (day)	45			
ABSV (V)	14.0			
ATIM (Hr)	2.0			
FLTV (V)	13.8			
HYST (V)	0.4			
BRTN (V)	12.3			
CHRG (A)				
PL20	20			
PL40	40			
PL60	60			
BFRQ (Day)	15			
TCMP	0			

SET/MODE	Setting for program number			
	0	1	2	3
Parameter	0	1	2	3
LSET	1	1	4	4
GSET	2	2	9	9
BSET	0	0	2	2
BAT2 (V)	14.0			
PWM	1			
ALRM (V)	11.4			

SET/EVNT	Setting for program number			
	0	1	2	3
Parameter	0	1	2	3
STRT	12			
TIME (Hr)	0			
STOP	12			
TIME (Hr)	25.5			
EMOD	2			
TMOD	0			

Settings for Program 4

If program 4 is selected, then all menu items can be accessed.

After TIME, VOLT and PROG, there are entry points for three further sub menus:

REG Allows you to customise the regulation settings for the PL (see below for details).

MODE Allows you to adjust other configuration options for the PL.

EVNT Settings for the event controller.

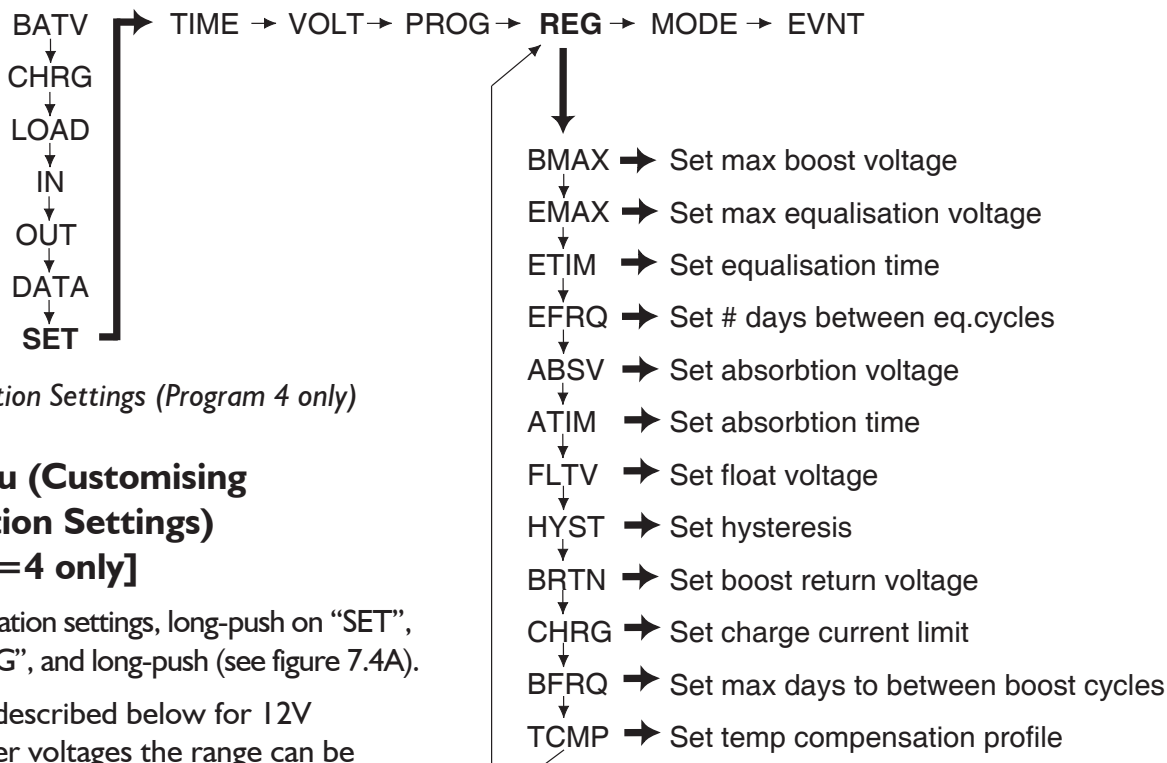

Fig. 7.4A - Regulation Settings (Program 4 only)

7.4 REG menu (Customising Regulation Settings) [PROG=4 only]

To adjust the regulation settings, long-push on “SET”, short-push to “REG”, and long-push (see figure 7.4A).

The settings are described below for 12V systems. For other voltages the range can be scaled from this. (eg. for a 24V system, multiply all voltages by 2.)

SET/REG Submenu Summary:

Name	Description	Range
BMAX	Maximum voltage in boost mode	13.5-16.5V
EMAX	Equalisation voltage	14.0-17.0V
ETIM	Equalisation time	0-2.0 hours
EFRQ	Number of days between equalisation cycles	20-150
ABSV	Absorption voltage	13.5-15.5V
ATIM	Absorption time	0-4.0 hours
FLTV	Float voltage	13.0-15.0V
HYST	Hysteresis used when not in PWM mode	0.1-1.0V
BRTN	Voltage below which return to Boost mode occurs	11.0-13.0V
CHRG	Charge current limit	PL20 0.5-20A
		PL40 0.5-40A
		PL60 0.5-60A
BFRQ	Maximum number of days between boost cycles	1-20
TCMP	Selection of temperature compensation profile (see following)	0-8

7.4.1 HYST (Hysteresis Value)

When not in PWM mode, the PL controls the battery voltage by simply switching the charge current on and off. It turns off the charge current at the relevant set point for the state (Float, Boost, Equalise, Absorption), and allows the charge current to turn back on at a slightly lower voltage. The gap between the two voltages is called hysteresis.

Example:

With the PL in float mode and slow switching (non PWM), the charge current will be turned on until the battery voltage rises to the FLTV value. Once the FLTV value has been reached, the charge current will be turned off until the battery voltage falls to FLTV – HYST (float voltage minus the hysteresis value) at which time the charge current will be turned on again until the battery reaches FLTV and the cycle begins again.

The larger the hysteresis values, the slower the rate of switching on and off will be.

NOTE: If you are switching a mechanical relay for regulation purposes, you may need to increase the HYST value so that the relay is not switching as often.



Timers:

The HYST value is also used to start and stop the timers associated with the different regulator charging states (Boost, Equalise, and Absorption).

Example:

When the PL changes to the Absorption state, an internal timer is started to monitor how long the regulator has been in Absorption. If however the battery voltage falls lower than ABSV - HYST this timer is stopped, and starts again when the battery voltage rises above ABSV - HYST. This ensures that the regulator holds the system in the required state for the correct programmed time and doesn't continue to the next charging stage until this time has elapsed.

NOTE: An exception to this is the Equalise State, which will terminate after 4 days if unable to complete the full specified time period.

7.4.2 Charge Current Limit

The PL has a built-in charge current limit. If the charge current exceeds the CHRГ setting, the PL will reduce the duty cycle to limit the average charge current.

This allows the PL to protect itself from overheating due to excessive charge current. The maximum charge current can also be limited for small batteries where the full array current might be too much for the battery. This is useful for systems, which are marginal in winter, but have too much charge current for the battery in summer.

It can also be useful where there is an initial ageing effect in the first few months of the life of the module. For example, with amorphous modules the initial current may be more than the charge current rating of the PL. Making use of this feature, you can install panels with the full rating calculated after the initial drop off.

7.4.3 TCMP (Temperature compensation)

(Default=0, Adjustable in Program 4 only)

A temperature sensor is available which allows the PL to adjust its regulation voltage settings to compensate for variations in battery temperature.

SET/REG/TCMP Selection Summary:

TCMP	Function	Data Source
0	-5mV°C linear auto sense (default)	General Purpose - use this if in doubt
1	gentle curve auto sense	BP Solar Block
2	steeper curve auto sense	Sonnenshein Dry Fit
3	limited range curve auto sense	Absolyte battery
4	-5mV°C linear non auto sense	General Purpose - use this if in doubt
5	gentle curve non auto sense	BP Solar Block
6	steeper curve non auto sense	Sonnenshein Dry Fit
7	limited range curve non auto sense	Absolyte battery
8	No temperature sensor	(Failsafe: if short across T- T+ inputs)

Note: Without temp sensor fitted, the PL will display 0°C.

The setting TCMP is used to select a temperature profile, which determines how this compensation is achieved.

The PL can automatically sense the presence of a temperature sensor if one of the auto-sense profiles is selected. If operation at temperatures near zero is common, it is better to use the non auto sense profile (TCMP=4-7).

Fig. 7.4.3B shows the temperature compensation curves for each TCMP setting. Consult your battery manufacturer for correct compensation for the battery used.

Connecting a Temperature Sensor

The temperature sensor should be connected to the T+ and T- terminals in the green terminal block (under the lid, above the top left corner of the LCD screen). The sensor wire with the stripe goes to the T- terminal and the sensor wire without the stripe goes to T+ terminal. The wires may be extended if necessary without affecting the accuracy.

Note: The PLTB (bolt-on metal lug) has no electrical connection to metal lug housing, so it can be connected to either the negative or positive battery terminal.

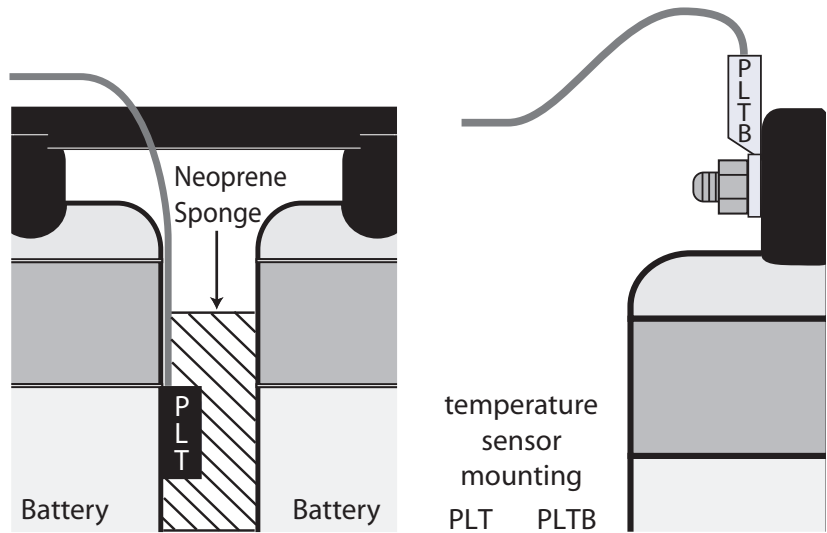

Fig. 7.4.3A - Attaching a Temperature Sensor to a battery

Non-Autosense should be used if battery temp likely to go below 0°C

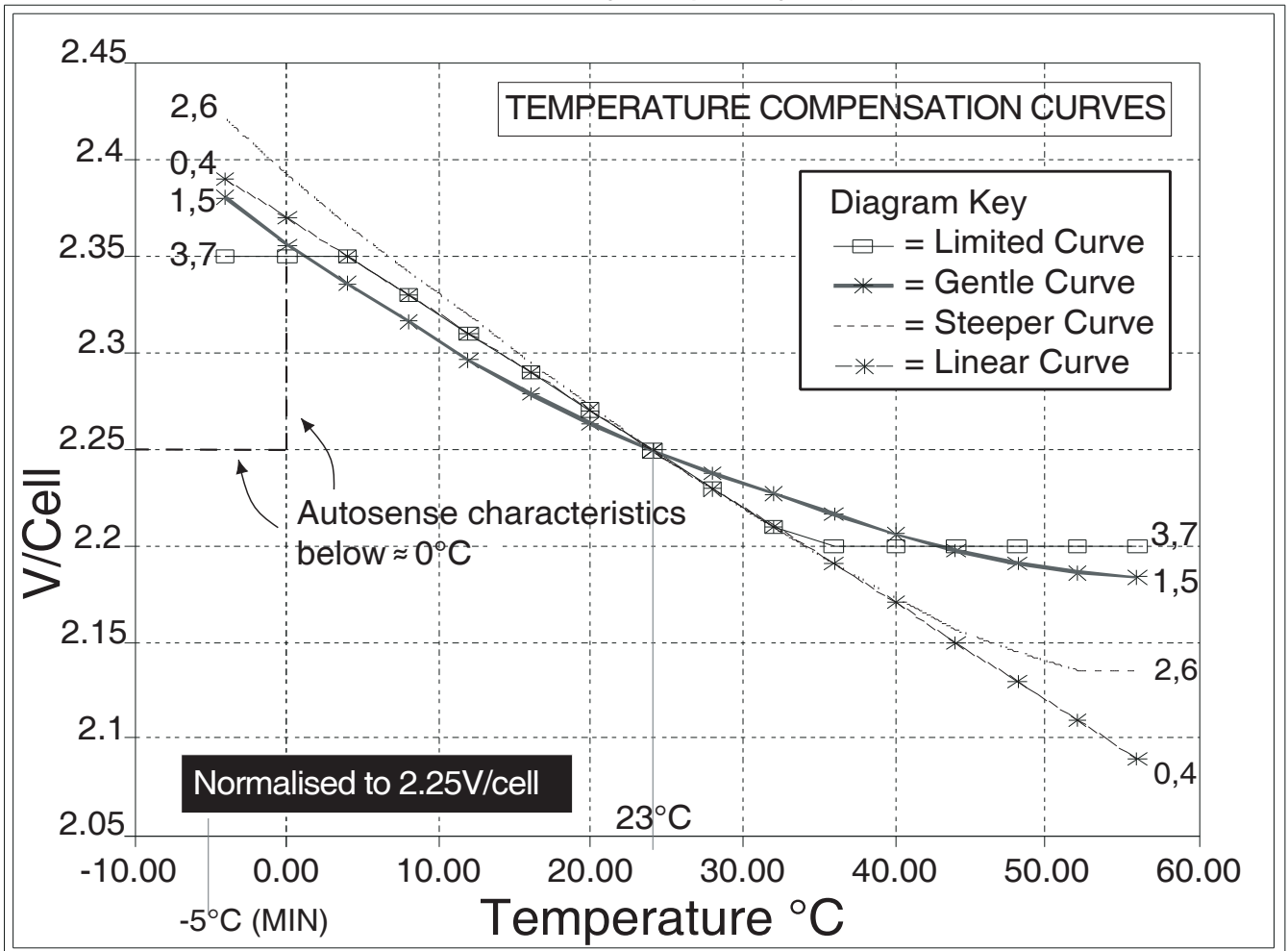

Fig. 7.4.3B - Temperature compensation curves

7.5 MODE Menu (Adjusting Configuration Settings) [PROG=4 only]

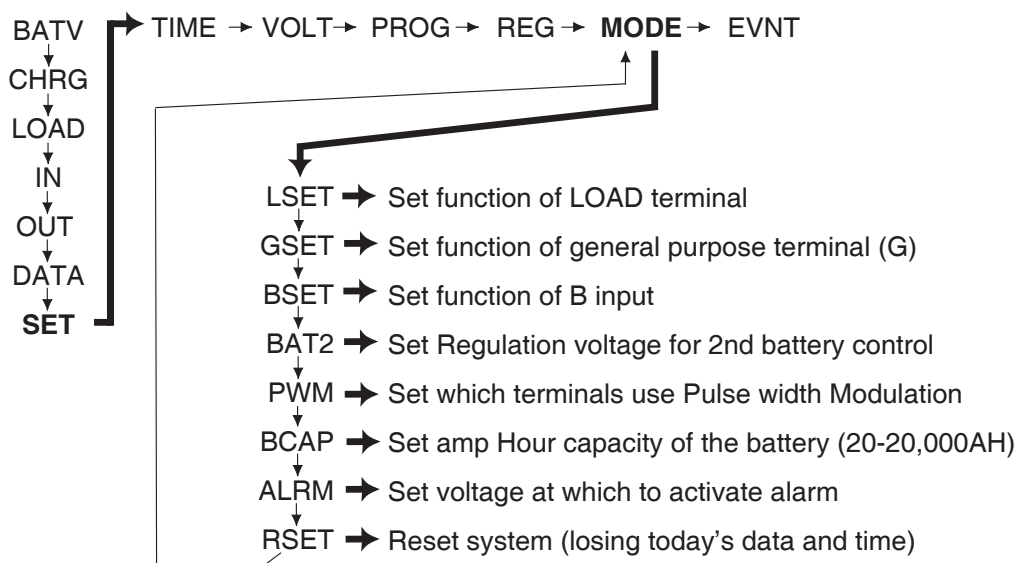

Fig. 7.5A - MODE Menu

The MODE submenu contains the settings for the configuration of the PL.

SET/MODE Selection Summary:

Name	Description	Range
LSET	Select the use of the LOAD-	0-11
GSET	Select the use of the "G" terminal	0-11
BSET	Select the use of the B- sense input	0-2
BAT2	Regulation voltage for 2nd battery control	13.0-16.0V
PWM	Select which terminals use PWM (SOL-, LOAD-)	0-3
BCAP	Amp hour capacity of the battery bank	20-20,000Ah
ALRM	Alarm voltage	10.0-18.0V
RSET	Resets today's Performance Data to zero.	

7.5.1 & 7.5.2 LSET & GSET

There are two output terminals on the PL (LOAD- and "G") and six logical functions. The LSET and GSET settings define which of the six functions controls each of these output terminals.

Note that the settings described below are different from the LSET and GSET screens described in Section 2 and 3.

The PL's six internal "functions" are normally used as follows:

- one function activates the low battery disconnect, and turns on the "LOAD" indicator on the bottom of the PL's screen.
- another activates a backup generator, which also turns on the "GEN" indicator on the bottom of the PL's screen.
- a third function determines when to start charging a second battery.
- a fourth function determines when to trigger (turn on) a low battery alarm output.
- a fifth function controls shunt regulation.
- a sixth function is used by the event controller to determine when the pre-set event should occur.

SET/MODE/LSET

#	Function	Terminal is:
0	Low battery disconnect	on when function wants to disconnect battery
1	Low battery disconnect (default)	off when function wants to disconnect battery
2	Generator control	on when function wants to run generator
3	Generator control	off when function wants to run generator
4	Event control	on when event is on
5	Event control	off when event is on
6	2nd battery charge control	on when battery 2 should charge
7	2nd battery charge control	off when battery 2 should charge
8	Alarm output	off when battery voltage < alarm setting
9	Alarm output	on when battery voltage < alarm setting
10	Shunt control (Must be selected for PWM control of the LOAD-terminal)*	off when function wants to disconnect the shunt load (ON for regulation)
11	Shunt control (PWM must not be set to 2 or 3)*	on when function wants to disconnect shunt load (OFF for regulation)

* Don't use LSET=11 with PWM, as design does not allow inversion of PWM signal.

The LSET setting allows you to choose which function controls the LOAD- terminal, and whether the terminal is on or off when the function is active. The GSET setting allows you to choose which function controls the general purpose "G" terminal (under the cover), and whether it is on or off when the function is active.

SET/MODE/GSET

#	Function	Terminal is:
0	Low battery disconnect	on when function wants to disconnect battery
1	Low battery disconnect	off when function wants to disconnect battery
2	Generator control (default)	on when function wants to run generator
3	Generator control	off when function wants to run generator
4	Event control	on when event is on
5	Event control	off when event is on
6	2nd battery charge control	on when battery 2 should charge
7	2nd battery charge control	off when battery 2 should charge
8	Alarm output	off when battery voltage < alarm setting
9	Alarm output	on when battery voltage < alarm setting
10	Shunt control**	off when function wants to disconnect shunt load (ON for regulation)
11	Shunt control**	on when function wants to disconnect shunt load (OFF for regulation)

** Note: PWM not available on G Terminal

Shunt Control

The PL supports either series control, shunt control, or both at the same time. In a hybrid system, the main solar component is controlled by the SOL- input and the other charge component (wind, hydro, etc) is managed by shunt control via the LOAD- or 'G' terminal switching in a 'dump load', either directly or with a relay. These functions are configured in the LSET and GSET screens. (see section 7.5.1 and 7.5.2)

Regulating Wind / Hydro:

Shunt control is appropriate for wind generators or microhydro systems, which require a constant load on the charging, source so the generator doesn't overspeed and destroy itself. In this case the charging source must remain connected to the battery at all times.

"Shunt control" (also referred to as "diversion control") refers to the technique of controlling the battery voltage by drawing energy from the system with a 'dump load', rather than disconnecting the charge source as "series control" does on the solar input.

To regulate a wind or microhydro installation with shunt control, a dedicated dump load must be available for the PL to switch across the battery. The dump load must be larger (at the range of expected battery voltages) than the maximum charge current available from your generator.

The function of the dump load is to 'soak up' energy coming in which the battery cannot store in order to maintain the desired battery voltage.

7.5.3 BSET: Configuring B- Sense Input

SET/MODE/BSET Selection Summary:

Selection	Function
0	B- input used for battery negative voltage sensing
1	2nd battery voltage sensing
2	external input VEXT, used by event controller

The input labelled B- (part of the green terminal block under the cover) is intended as a sense input for the battery negative voltage. This can be connected directly to the battery negative terminal and will read the true battery negative voltage. This is important if there is significant voltage drop along the wiring (including the fuse) between the BAT- terminal on the PL and the real battery negative. (If there is significant voltage drop on the positive side, then take the BAT+ terminal on the PL20/40 directly to the battery positive via a fuse. The fuse need only be rated for the PL current, say 200mA. Take the charge current from the array to the battery separately via it's own fuse. The idea is that the array current is not passing through the same wire as the PL positive supply current). Alternatively on the PL60, connect the B+ terminal directly to the battery positive terminal.

If the B- input is not being used for this, then it can be used for sensing the voltage on a second battery being charged or for providing a voltage input for the event controller (Push button or VEXT).

'Push Button' Switch Input

If you wish to use the B- sense input as a switch event input, you must wire a switch or other trigger between the B- terminal (green terminal block) and the Bat- terminal (with BSET = 2).

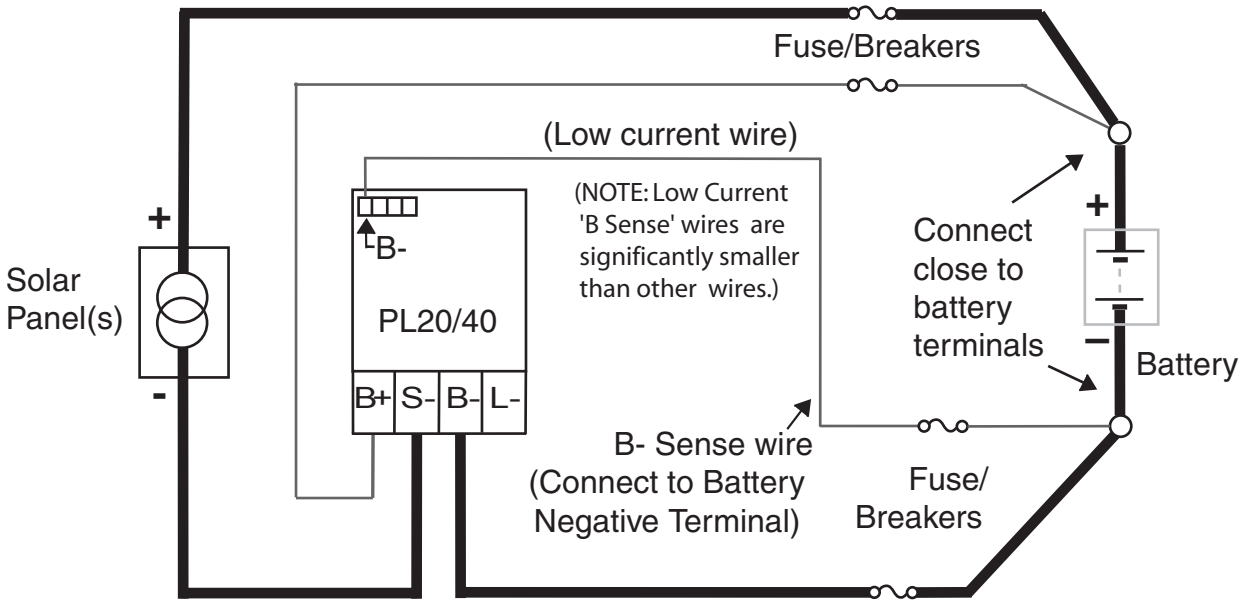
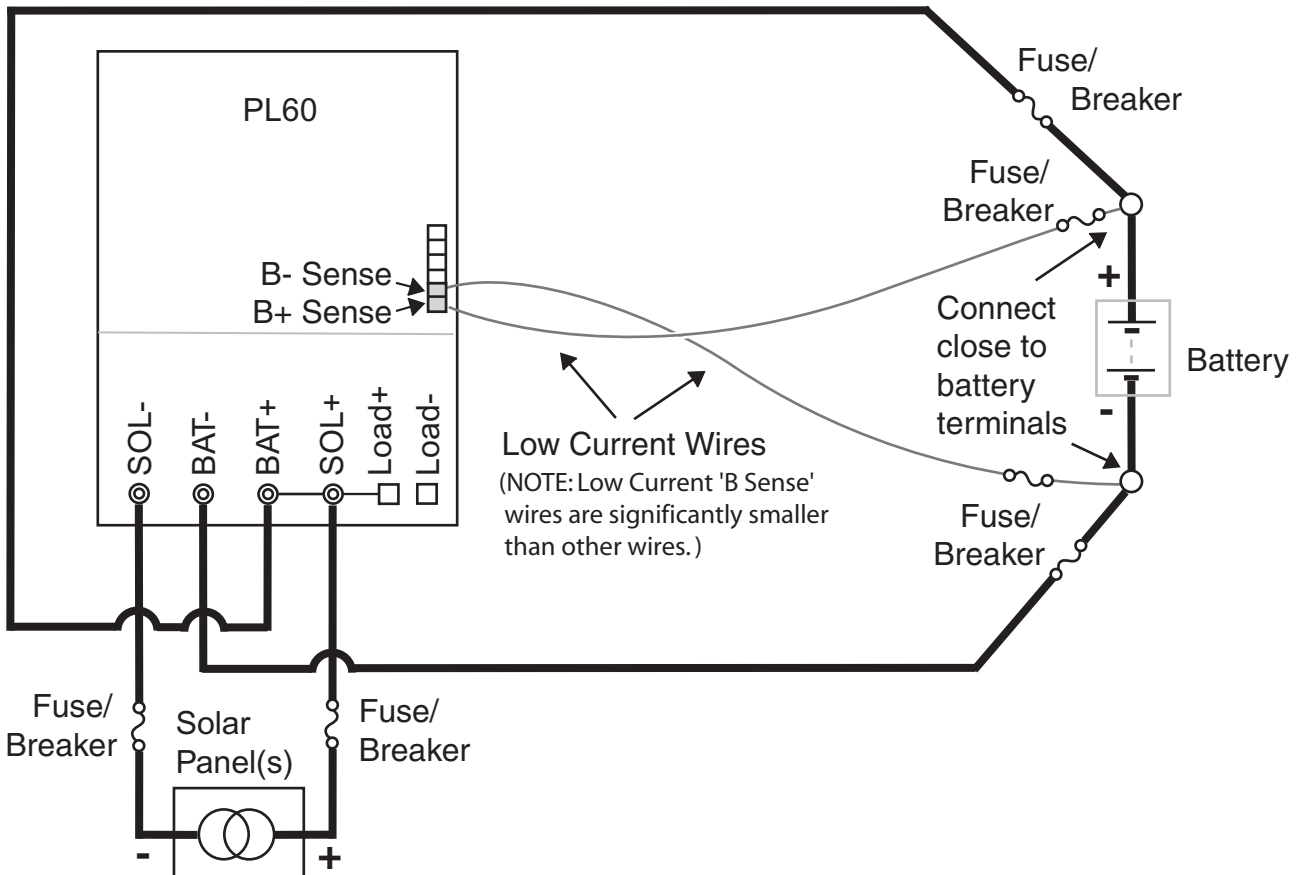

Fig. 7.5.3A - Battery Sense Input

Fig. 7.5.3B - Battery Sense Input



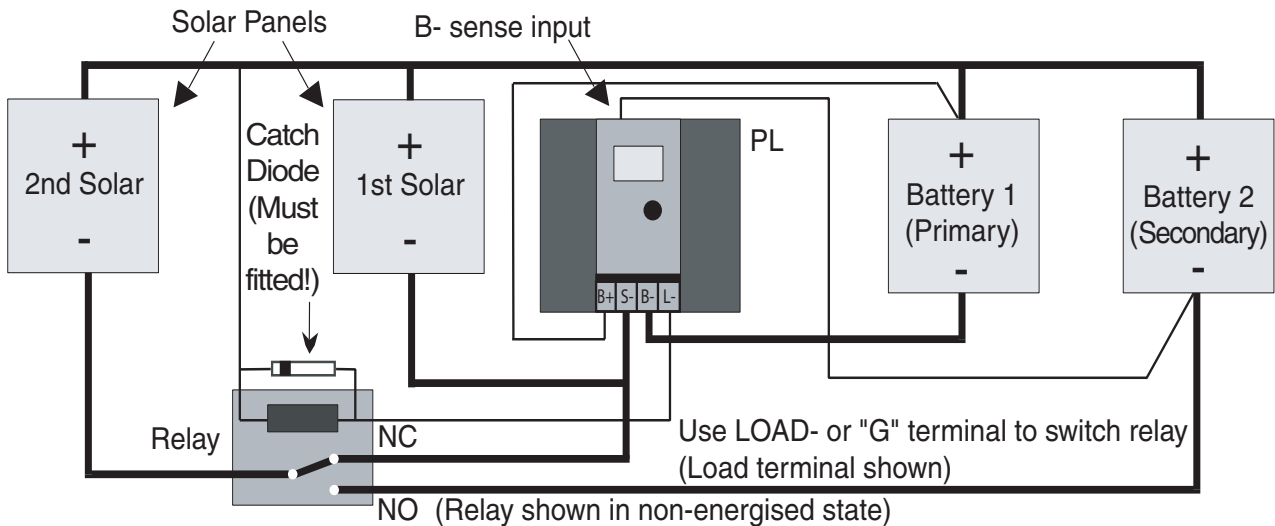

Fig. 7.5.4A - Second Battery Control

7.5.4 BAT2 - Second battery control

Second Battery Control uses a relay to switch the panel negative from the primary battery to the secondary battery.

On many afternoons, there is power available from the solar panels but it is wasted because the batteries are already full by then. This power could be used to charge a second or reserve battery bank. The PL has a separate single stage controller for a 2nd battery built into it. This only allows the second battery to charge if the PL has reached the float state and the voltage on the 2nd battery is below the setting in the BAT2 screen.

NOTE: Second battery control is not suitable for use in negative ground systems such as many vehicles, since it uses the B- sense input and requires the battery negative terminals to be separated (i.e not both connected to the chassis)

With the positives of the two batteries joined together, the PL can read the voltage on the second battery from the B- sense input. An external switching device such as a changeover relay will be required to switch the negative of the solar panel(s) from the SOL- terminal of the PL to the negative terminal on the second battery (see fig 7.5.4A).

You can use either the Load Terminal or 'G' Terminal for switching the relay (keep in mind that the 'G' terminal max current is only 120mA for the PL20 and PL40, and 300mA for the

PL60). A 'Catch Diode' must be fitted across the relay in either case. The end of the diode with the band goes towards BAT+.

The following settings will also need to be configured:

PROG=4	allows changing LSET, GSET, BSET etc
LSET=6 or GSET=6	LSET if using load terminal for relay, GSET if using the 'G' Terminal for relay
BSET=1	'B-' input used for 2nd battery control

The 'B-' sense input is wired to the negative terminal of the secondary battery and allows voltage monitoring of the secondary battery voltage. This allows the regulator to perform basic single stage regulation of the secondary battery by switching the relay on or off to connect/disconnect the charge source. You do NOT need a second regulator.

The relay you use will need to meet the following minimum specifications:

- Correct coil voltage to match your system, i.e. able to handle the maximum battery voltage.
- Output contacts rated for DC current.
- Output contacts rated to handle the maximum current that the connected panels can output.

Note: It is suggested that customers leave some panels permanently connected to the regulator

SOL- input (1st solar) and switch all the other panels (2nd solar) across with the relay. This leaves a regulated 'maintenance' charge available for the primary battery, and can minimise the amount of switching required by the relay (which switches over each time the primary battery bank voltage falls below FLTV - HYST). The maximum relay switching rate = 30 sec

Consider: Are you sure that this setup is the best use of available charge current? Consider if it would be better to increase your primary battery bank.

7.5.5 PWM and Slow Switching

SET/MODE/PWM: [PROG= 4 Only]

Selection	Function
0	No PWM used
1	PWM on SOL- terminal only
2	PWM on LOAD- terminal only
3	PWM on both

When the PL is trying to keep the battery voltage constant, it does this by turning the charge current on or off as required. It can do this quickly or slowly.

PWM (fast switching):

In the fast switching mode, the PL uses pulse width modulation (PWM) at 125Hz. It is recommended that PWM control be used unless there is good reason not to, as it provides much smoother control and faster charging.

PWM may generate some audio or radio frequency interference. If you experience noise on electronic equipment (for example AM radio), you could try selecting SET/MODE/PWM = 0 (slow switching only, option available when PROG=4). If this does not fix the problem, it's unlikely that the noise is generated by the PL controller.

The radio frequency interference from the PL has been tested in PWM mode and found to be very low. It is at least 15dB below the domestic limit for European and Australian EMI compliance standards.

NOTE: More care must be taken at higher system voltages (particularly 48V) because the inductance

of the wiring to the photovoltaic panels can cause some 'ringing' on turn-off. Keep wiring as short as possible and panel cable pairs together (cable tie). On long wiring runs at higher voltages, some damping may be necessary and possibly some external clamping of transients. With highly inductive wiring, the transients may be large enough to damage the FET switch. Consult the factory if further information is required.

LOAD- terminal PWM switching:

For PWM control to be available on the LOAD-terminal, LSET must be set for Function 10 (Shunt Control). **DO NOT set LSET to Function 11 (Inverted Shunt Control) if using PWM on load terminal—see the LSET table.**

PWM should only be enabled on the LOAD-terminal (PWM = 2 or 3) if the PL is using the LOAD-terminal to directly switch a dump load (no relay).

An exception to this is when the LOAD-terminal is driving a solid state 'electronic' relay (non-mechanical), as these can usually switch at PWM speed (125 Hz).

NOTE: PWM is not available on the 'G' terminal.

Slow Switching (non PWM):

In slow switching (non PWM) mode, the PL controls the battery voltage by slowly switching the charge current on and off. It turns the charge current *OFF* at the voltage set point for the relevant charge state, and turns the charge current back *ON* at a slightly lower voltage.

The gap between these two voltages is called hysteresis and is adjustable (HYST). The larger the hysteresis value, the slower the rate of switching on and off will be.

HINT: Increase Hysteresis value if you are using shunt control with a mechanical relay so the relay is switching less often.

In the slow switching mode, the regulator limits the *maximum* switching speed to 0.25 seconds between changes. This virtually eliminates any audio or radio frequency interference.

7.5.6 BCAP

BCAP sets the effective Amp-hour capacity of the battery being charged by the PL. This is used by the State of Charge data screen. A long push on BCAP allows you to set this value. You should set the battery capacity you actually expect as discussed in Section 6.4 (SOC).

BCAP's range is 20Ah-20,000Ah. Short pushes will increment BCAP by 20Ah until it reaches 1000 Ah. At this point, the increment increases to 100Ah and the display changes to thousands - i.e. 1000 is displayed as 1.0, and 1100 as 1.1. When the display reaches 20,000Ah (shown as 20.0), it will cycle back to 20Ah (shown as 20). It's important that you take notice of the difference. If you intend to set 20,000Ah you would not want 20 Ah instead. The two appear one after the other on the PL display during setting. The only visible difference is the decimal point to show 20,000 Ah.

7.5.7 ALRM

Long-push here to set the alarm voltage. If the battery voltage falls below the alarm voltage, the PL will activate its internal Alarm function. If the LSET / GSET settings have been configured appropriately, this can be used to set off an

Example - Battery Low Alarm Output

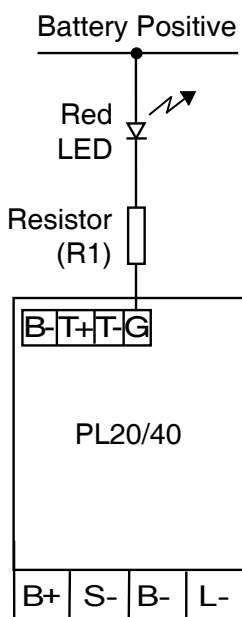

Fig. 7.5.7A - Alarm Wiring

audible alarm (or any other type of alarm) connected to the LOAD- or 'G' terminal. There is no audible alarm built into the PL. The PL can send a signal or power to an external alarm of some kind.

System	RI Value
12V	1K, 1/4W, 5%
24V	2K2, 1/2W, 5%
48V	4K7, 1W, 5%

(Higher wattage resistors may be used)

RI values are calculated to give adequate LED brightness at low battery voltage, but not burn-out at high battery voltages (eg. in case output function changed by mistake).

Settings:

SET / PROG=4
SET / MODE / GSET=9 (on when battery voltage < alarm setting)
SET / MODE / ALRM=11.4V (for example. Set as required.)

7.5.8 RSET

A long-push on RSET will reset today's Performance Data and the clock to zero (midnight).

Note that you will need to re-enter the current time on the PL's internal clock, but your other settings and history will be retained.

Also note that any 'quiet-time' functions will not work until the clock is reset since midnight is a 'no-go' time zone!

7.6 EVNT Menu (Event Control)

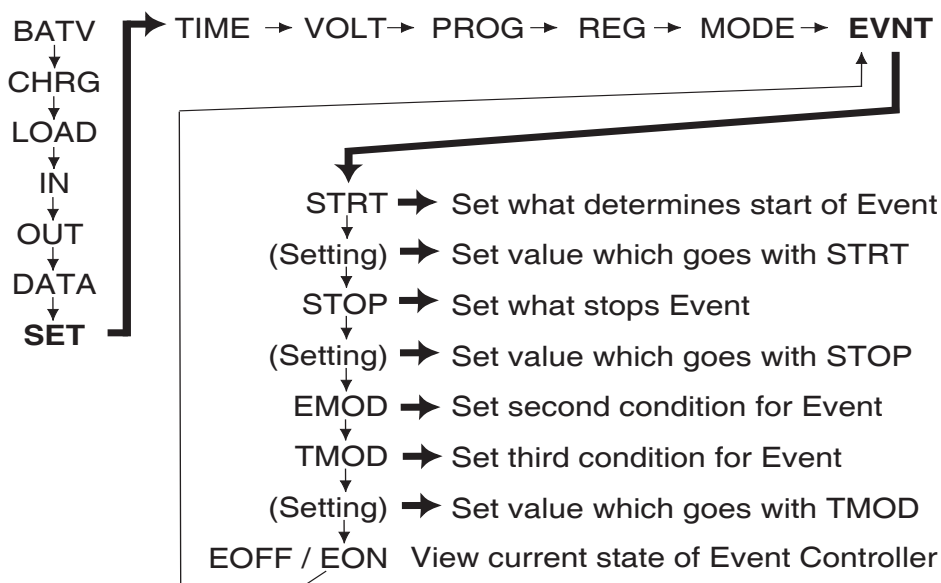

Fig. 7.6A - Event Control Menu [PROG = 4 only]

The event controller allows something to happen when a set of conditions is met. There are an unlimited number of applications for this feature, such as:

- Turning on a light at night
- Using ‘waste’ energy pumping water in the afternoon if the PL is in the float state
- Sensor operated timed lighting at night
- Turning on sprinklers for an hour if it’s over a certain temperature

(to use the “G” General Purpose terminal). The use of these is described in Section 7.5. To use the event controller, one of these settings must be set to “4” or “5”.

Step 3 - Set the STRT condition.

The PL must be told what signifies the start of the event. Move to the EVNT menu, as shown in Figure 7.6A. A long-push on EVNT will move to the STRT setting. STRT uses the following table to determine what will start the event:

Using the Event Controller

Step 1 - Select PROG 4

Many users will not need the event controller, so in Programs 0-3 it is automatically disabled. For users who do wish to use the event controller, Program 4 must be selected.

Step 2 - Set LSET or GSET

It is necessary to tell the PL which output terminal will be controlled by the Event Controller. This is done using the LSET setting (to use the LOAD- terminal) or the GSET setting



SET/EVNT/STRT Selection Summary

STRT	Event starts when	Value to set
0	Solar panel voltage (open circuit) > setting #	SOLV
1	Solar panel voltage (open circuit) < setting #	SOLV
2	External voltage VEXT * > setting	VEXT
3	External voltage VEXT * < setting	VEXT
4	PB** is on and time > setting	TIME
5	PB** is off and time > setting	TIME
6	Not Used	--
7	Not Used	--
8	Repeat start at 10 min intervals if time > setting	TIME
9	Repeat start at 30 min intervals if time > setting	TIME
10	Repeat start at 1hr intervals if time > setting	TIME
11	Repeat start at 2hr intervals if time > setting	TIME
12	Time > setting (0.0-23.9)	TIME
13	Not Used	--
14	Repeat start at a set rate (0-240 min)	RATE
15	Repeat start at a set rate (0.0-24.0h)	RATE

#Note: After up to 6 min delay.

* Note: VEXT is the voltage on the B- sense input ($\pm 8V$ relative to BAT- terminal). To configure the B- sense input for this purpose, make BSET=2. This is offset so that 80 on the VEXT setting screen is 0V. It is scaled in 0.1V steps so that +2V is represented by 100, or -3V is represented by 50.

**Note: "PB" means a push-button switch. If you wish to use this option, you must wire a switch or other trigger between the B- terminal (green terminal block) and the BAT- terminal, and make BSET = 2.

After setting the STRT value, a short-push will move you to the setting, which goes with that STRT value. For example, if you set STRT to "1", you will see SOLV. Whenever the solar panel voltage drops below the value you set in SOLV, the "event" will start.

Step 4

Use the STOP setting to tell the PL what signifies the end of the "event".

The STOP setting uses the following table:
SET/EVNT/STOP Selection Summary

STOP	Event stops when	Value to set
0	Solar panel open circuit voltage > setting #	SOLV
1	Solar panel open circuit voltage < setting #	SOLV
2	External voltage VEXT * > setting	VEXT
3	External voltage VEXT * < setting	VEXT
4	PB** off and time > setting	TIME
5	PB** on and time > setting	TIME
6	Not Used	--
7	Not Used	--
8	Repeat stop at 1 min intervals if time > setting	TIME
9	Repeat stop at 3 min intervals if time > setting	TIME
10	Repeat stop at 6 min intervals if time > setting	TIME
11	Repeat stop at 12 min intervals if time > setting	TIME
12	Time > setting (0.0-25.2)	TIME
13	Not Used	--
14	Stop after a set run time (0-240min)	RUN
15	Stop after a set run time (0.0-24.0h)	RUN

#Note: After up to 6min delay.

*Note: "VEXT" has the same meanings as in the STRT table.

**Note: "PB" has the same meanings as in the STRT table.

After setting the STOP value, a short-push will move you to the setting, which goes with that STOP value.

For example, if you set STOP to “12”, you will see TIME. The “event” will then continue until the time is after the time you specify in the TIME setting. One use of this combination of STRT and STOP could be to turn a light on between dusk and 11pm.

Step 5

Next, a short-push brings the EMOD setting and then the TMOD setting. These settings can be used to set more conditions, which determine the event.

For example, the EMOD setting can be used to ensure the light only turns on if the PL is in the Float state (EMOD=1).

If additional conditions are not needed, they can be set to zero and they will be disregarded (always active).

SET/EVNT/EMOD Selection Summary

EMOD	EMOD is active when:
0	Always active (ie EMOD condition is irrelevant)
1	PL is in Float mode
2	it's night
3	it's day
4	Not used
5	PL is in Float and it's night
6	PL is in Float and it's day
7-11	Not used

SET/EVNT/TMOD Selection Summary

If you use TMOD settings 0-6, the Low Battery Disconnect (LBD) function overrides the Event Controller, and your battery will be protected. Using settings 8-14 allows the Event Controller to override the Low Battery Disconnect function, and your battery will not be protected.

Note: Use TMOD = 8 to 14 for any event that controls a charging source via a relay as you do not want the TMOD function being overridden by a low battery condition (LBD), i.e. TMOD 0 to 7 will override (and possibly turn off) the charge source when your battery gets low!

TMOD	TMOD is active when	Value to set	LBD
0	Always active (TMOD irrelevant)	None	Y
1	temperature > setting	TEMP	Y
2	temperature < setting	TEMP	Y
3	*VEXT > setting	VEXT	Y
4	*VEXT < setting	VEXT	Y
5	Time > setting	TIME	Y
6	Time < setting	TIME	Y
7	Do not use	—	—
8	Always active (TMOD irrelevant)	None	N
9	temperature > setting	TEMP	N
10	temperature < setting	TEMP	N
11	*VEXT > setting	VEXT	N
12	*VEXT < setting	VEXT	N
13	Time > setting	TIME	N
14	Time < setting	TIME	N

** Note: VEXT is the voltage on the B- sense input ($\pm 8V$ relative to BAT- terminal). To configure the B- sense input for this purpose, make BSET=2. This is offset so that 80 on the VEXT setting screen is 0V. It is scaled in 0.1V steps so that +2V is represented by 100, or -3V is represented by 50.*

After setting the TMOD value, a short-push will move you to the setting, which goes with that TMOD value, similar to STRT and STOP.



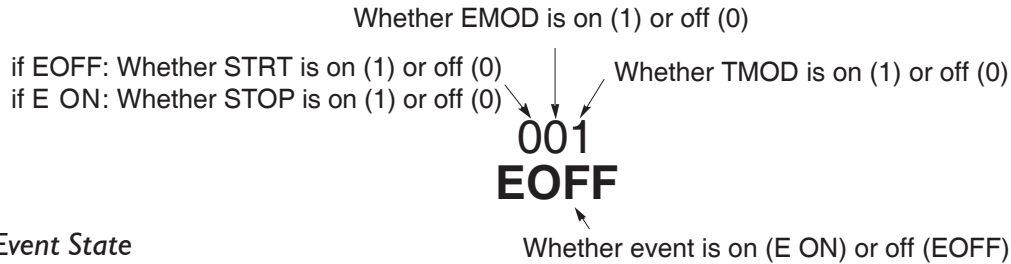

Fig. 7.7A - Event State

Step 6

Finally, a short-push displays a screen, which tells you the current state of each of the conditions, and whether the “event” is currently active.

If the “event” is inactive, then to turn it on all three conditions (STRT, EMOD and TMOD) must become active (ie. “1”).

When the “event” is active, if the STOP condition takes place or the TMOD or EMOD condition goes inactive (ie “0”), then the event will turn off.

If the display shows “E ON” then the “event” is currently active. If it shows “EOFF” then the “event” is currently not active, but will become active when all of the preset conditions are met.

The numeric figure shows the state of each of these conditions.

The first digit shows the status of the STRT and STOP conditions. If the event is off (EOFF), the first digit shows the state of the STRT condition (0 = inactive, 1 = active). If the event is on (E ON) the first digit shows the state of the STOP condition. In the example, above, this figure will be “0” during the day (i.e. STRT condition is inactive), then “1” at dusk when the solar panel voltage drops to the pre-set SOLV value. If the battery was fully charged, the event will start:

the display will change to “E ON” and the first digit will flick back to “0” to show that the STOP condition is inactive. If the battery was not fully charged, the event will not start, the display will stay on “EOFF”, and the first digit will remain on “1” until either the PL enters the Float state (when the event will start), or 1 Ipm comes (when it will flick to 0 until next evening).

The second digit shows the state of the EMOD condition. In the example above, this digit will be “1” when the battery is in the Float state, and “0” if it is in the Boost, Equalise or Absorption states.

The third digit shows the state of the TMOD condition. In the example above, TMOD was not used, and this digit will always be “1”.

Examples:

1. To turn a light on all night

STRT	TIME	STOP	TIME	EMOD	TMOD
12	0	12	25.0	2	0

The first four conditions have the effect of making STRT and STOP irrelevant. The STRT condition will always be on, and the STOP condition will never happen: the time will always be greater than 0 (midnight), and as the time returns to 0 after 23.9 (6 minutes to midnight), it will always be less than 25.0, which is a non-existent time.

In practice, the EMOD condition will determine whether the event is on or off. Because it is set to 2, it will be on at night. If a light is wired to the LOAD- terminal and LSET=4, then the light will turn on at night.

2. Pushing a button turns a light on at night for 10 minutes:

STRT	TIME	STOP	RUN	EMOD	TMOD
4	0	14	10	2	0

If a momentary ON push-button is wired up between B- and BAT-, the STRT condition will turn on with the push-button input (the time will always be greater than 0). It will stop after 10 minutes due to the STOP and RUN settings. EMOD=2 makes sure that this will only happen at night—during the day pressing the push-button will have no effect. Note: BSET=2, LSET or GSET=4

3. Pump water if battery is fully charged until tank is full (i.e. switch in tank turns off):

STRT	TIME	STOP	TIME	EMOD	TMOD
12	0	5	0	1	0

The STRT condition is always true, as the time is always greater than 0. However, until the PL switches into the Float state, EMOD will not be active. When the PL enters Float state, EMOD will become active and, as STRT is always true and TMOD is always true, the pumping will start. The STOP condition becomes true when a switch in the tank (wired between the PL's BAT and B- terminals) switches off (open), i.e. the tank is full.

Note: BSET=2, LSET or GSET=4

4. Water garden for 5 minutes every 100 min from 10am until nightfall

STRT	RATE	STOP	RUN	EMOD	TMOD	TIME
14	100	14	5	3	5	10.0

The STRT condition is true every 100 minutes, i.e. repeated start at 100 minute intervals. The STOP condition causes the event to run for only 5 minutes after each event start. This cycle will continue while it is daytime (EMOD = 3) and it is after 10am (TMOD = 5, set 3 = 10.0).

Note: LSET or GSET = 4

A.0 Appendices

A.1 'Catch diode' protection

LOAD	
PL20	1N5404 (or 1N5405/06/07)
PL40	1N4007 (or similar)
PL60	1N5404 (or 1N5405/06/07)
'G' Terminal	
PL20	1N4007 (or similar)
PL40	1N4007 (or similar)
PL60	1N4007 (or similar)

A.2 Accessories

There are accessories, which can enhance the usefulness of the PL controller.

External Battery Temperature Sensor (PLT or PLTB)

The PLT is a plastic-cased unit for direct attachment to the battery wall. The PLTB has a bolt-on lug for attaching to the battery terminal (either terminal).

The unit connects to the T+ and T- inputs on the green terminal block under the PL cover (above the top left corner of the LCD screen). See Section 7.4.12 for further details about this unit.

PLM, PLS2, PLI

The following accessories plug into the serial port which is under the lid on the left hand side, via a WY cable (PL20/40) or WZ cable (PL60).

Remote Control (PLM)

The PL can be accessed remotely with the remote control. All of the functions work in the same way as on the actual controller. Includes built-in audible alarm and display backlighting.

External Shunt Adaptor (PLS2)

Up to two external shunts can be added to the PL to allow it to measure larger currents than it is capable of measuring directly. The shunt adaptor measures the current in a shunt (eg SH200), converts it to digital information and sends that information back to the PL. The connection to the shunt is DC isolated from the PL so the shunt can be placed in any part of the circuit. Currents up to 250A can be read. See the PLS2 instruction sheet for more information.

Computer/Modem Serial Interface (PLI)

An RS232 level serial interface is available which allows the PL to communicate with a computer or be remote accessed via a modem. This is a quick way to load settings into the PL or extract performance data. All of the data is remotely accessible, and all settings can be adjusted. Software is available for IBM compatibles to make this easy. Data can then be loaded into a spreadsheet or other applications.

A.3 Specifications on PL20, 40, 60

Nominal system voltages	12,24,32,36,48	V
Maximum voltage BAT+ to BAT-	100	V
Max short term voltage BAT+ to BAT-	120	V
Maximum voltage BAT+ to SOL-	100	V
Max voltage LOAD- to BAT-	60	V
Max voltage "G" terminal to BAT-	60	V
Max voltage B- sense to BAT- (Reads $\pm 8V$ where $-8V=0$, $0V=80$, $+8V=160$)	+/-10	V
Max. continuous charge current (SOL-)		
	PL20	20 A
	PL40	40 A
	PL60	60 A
Max. continuous load current (LOAD-)		
	PL20	20 A
	PL40	7 A
	PL60	30 A
Max. short term* load current		
(*a few mins)	PL20	25 A
	PL40	10 A
	PL60	40 A
Max "G" terminal output current		
	PL20	120 mA
	PL40	120 mA
	PL60	300 mA
Battery Temp sensor range	-5 to 50	°C
Max. storage temperature	70	°C
Supply Current		
	PL20	9 mA
	PL40	14 mA
	PL60	20 mA
Meter Accuracy	< +/-2% +/-1 display digit	
Max wire size, Large square screw terminals PL20/PL40 (PL60 load) = 16mm ² = 6 AWG		
Wire size, Green Terminal Block = 0.14 - 0.15mm ² = 26-16 AWG		
PL60 termination stud	6mm diameter	

A.4.1 Block Diagram of PL20/40 Hardware

The PL Controller is designed for common positive installations (i.e. switches solar and load in the negative wire).

It has a reverse blocking mosfet switch between the SOL- terminal and the BAT- terminal and a mosfet switch between the LOAD- terminal and the BAT- terminal. There is also a low current mosfet switch between the 'G' terminal and the BAT- terminal used to drive a generator control or alarm relay.

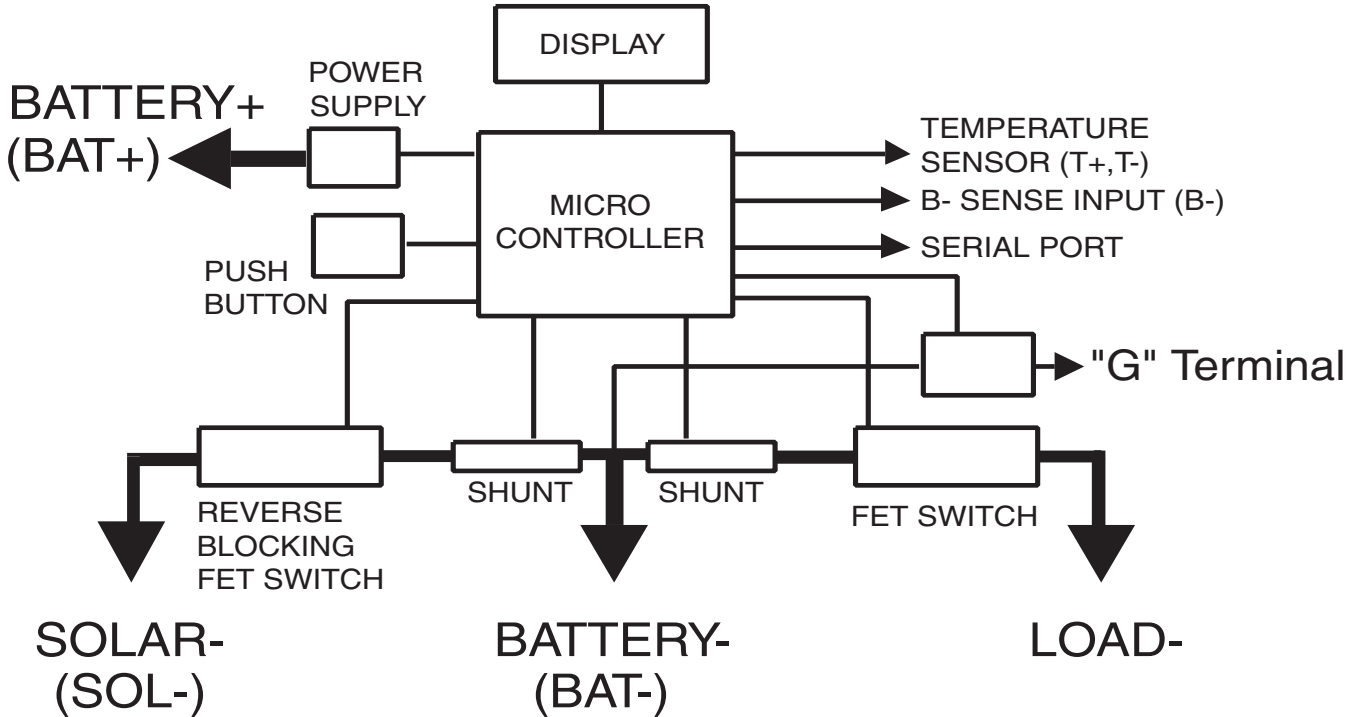

A.4.2 Block Diagram of PL60 Hardware

Note: Common positive configuration (ie switches solar and load in the negative wire)

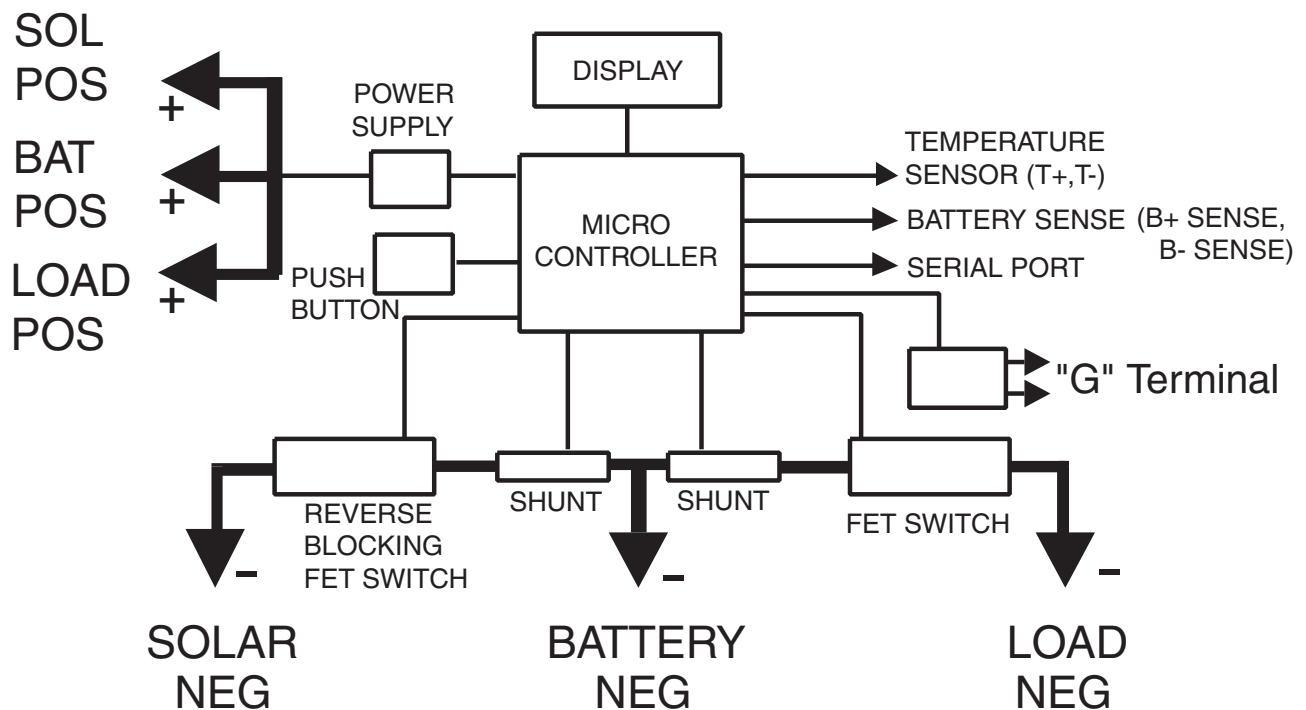

A.5 Thermal derating

The current rating of the PL must be reduced at high ambient temperatures or the display will darken until it is unreadable. The currents indicate what can be done at the same time. Because the limit is due to heating, there are many combinations of charge and load current which will produce the same heat level. This table shows the limits of some combinations.

Air temperature around the PL (°C)	Charge Current Max			Load Current Max		
	PL20	PL40	PL60	PL20	PL40	PL60
40°C	20 A	40A	60A	20 A	7A	30A
44	20 18 13	40 37	60	0 10 20	0	30
48	35	0	60			30
50	18 5 13	32	60	0 20 10	0	30
55	13 0	28	55 50	0 20	0	18 30

A.6 Mechanical Information

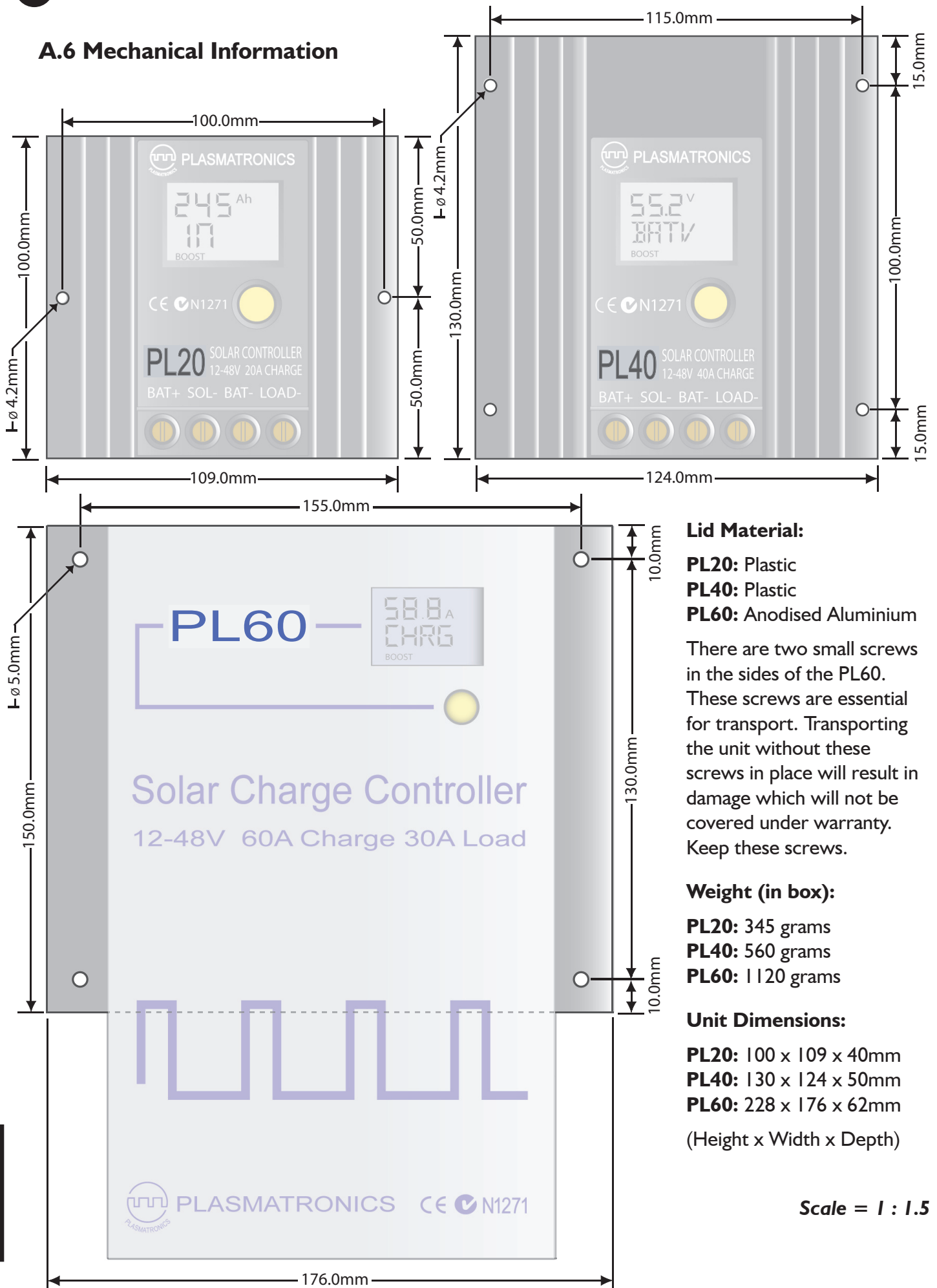

Lid Material:

PL20: Plastic

PL40: Plastic

PL60: Anodised Aluminium

There are two small screws in the sides of the PL60.

These screws are essential for transport. Transporting the unit without these screws in place will result in damage which will not be covered under warranty. Keep these screws.

Weight (in box):

PL20: 345 grams

PL40: 560 grams

PL60: 1120 grams

Unit Dimensions:

PL20: 100 x 109 x 40mm

PL40: 130 x 124 x 50mm

PL60: 228 x 176 x 62mm

(Height x Width x Depth)

Scale = 1 : 1.5



NOTES

Programs 0-3 Menu System (Generic programs)

———> Thin arrow = short push
 ———> Thick arrow = long push
 (Explained in User Guide p6)

Section:

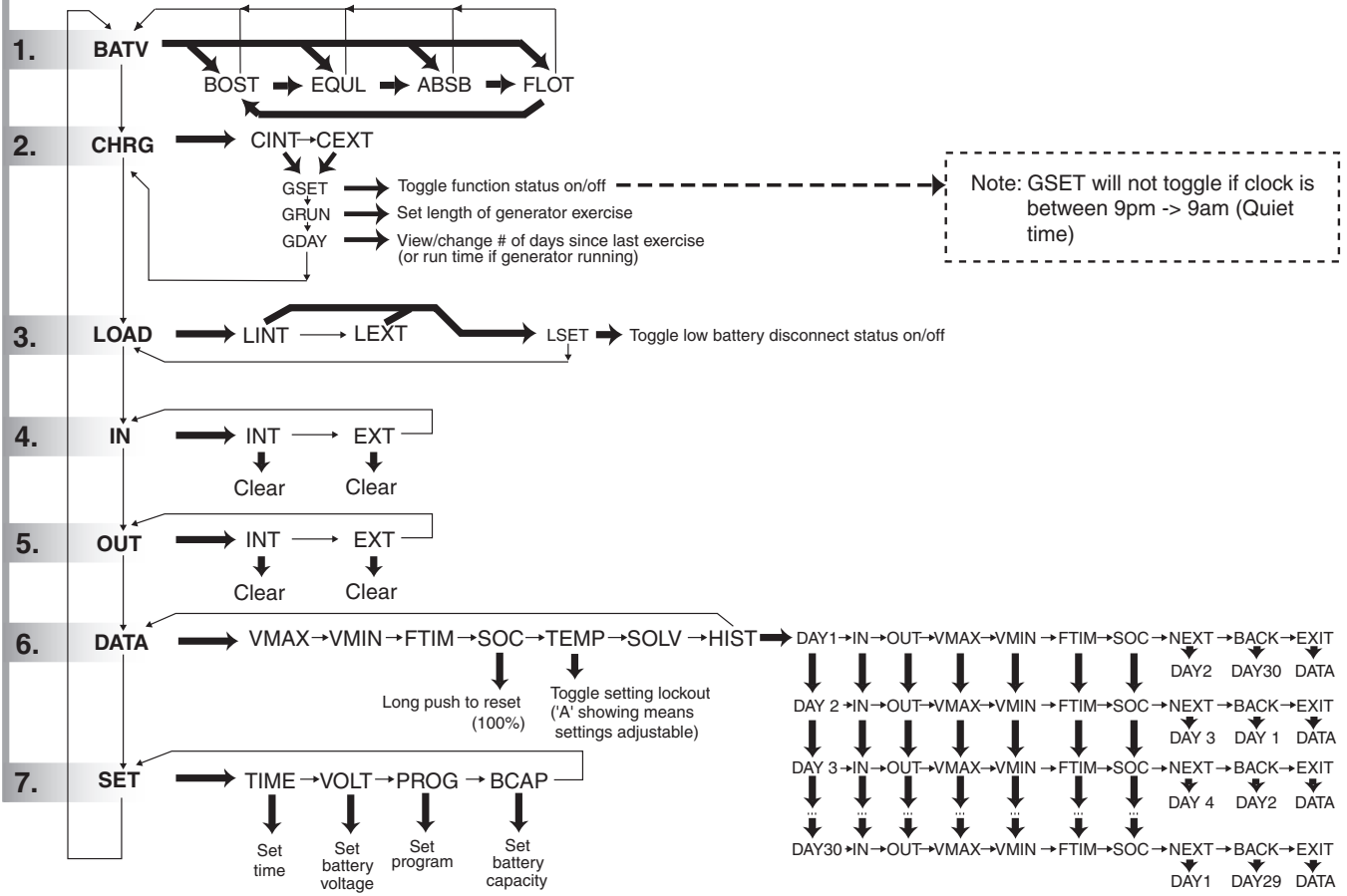

Note: GSET will not toggle if clock is between 9pm -> 9am (Quiet time)



Program 4 Menu System

(For custom settings)

→ Thin arrow = short push
 → Thick arrow = long push
 (Explained in User Guide p6)

Section:

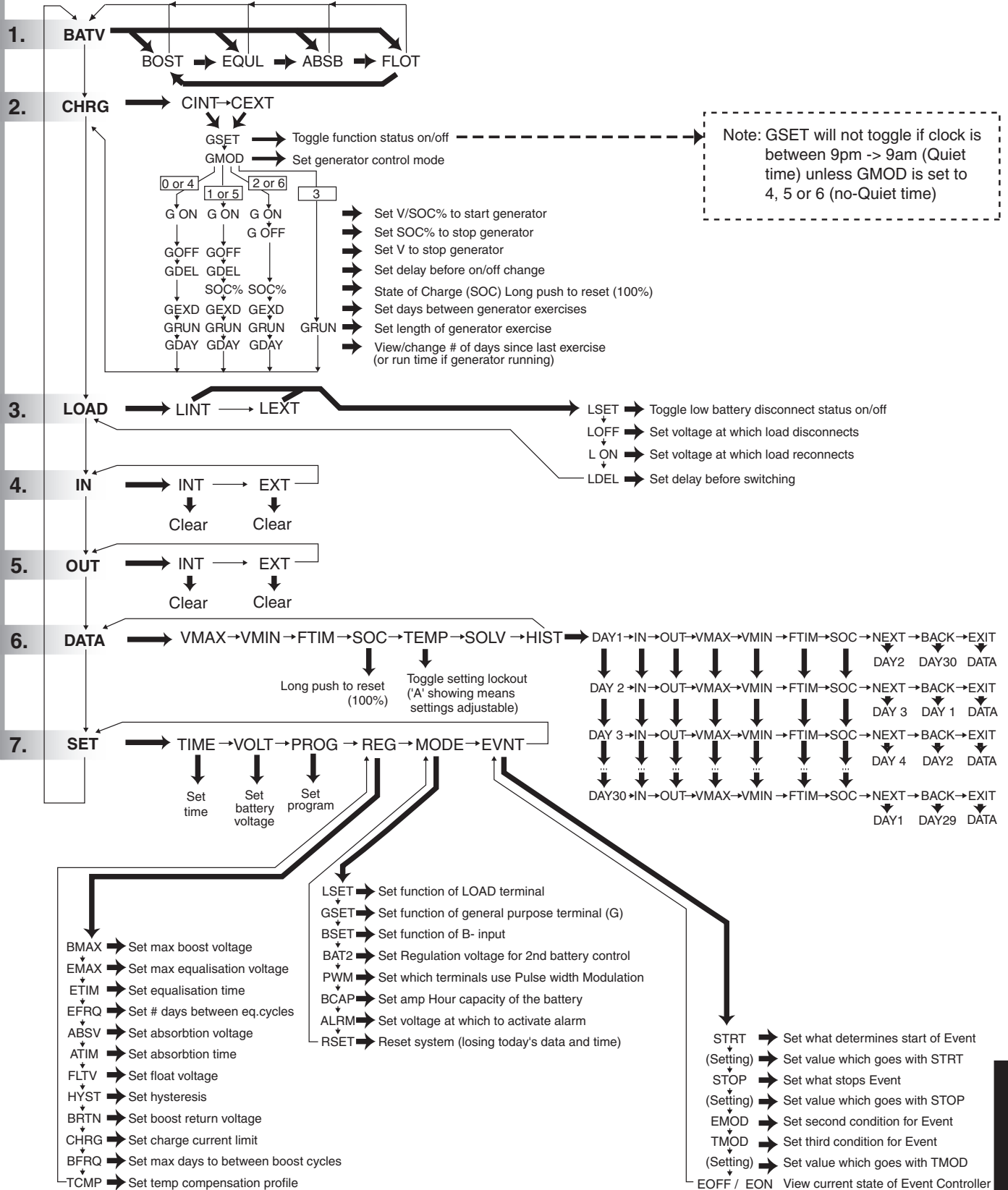

NOTES