

# **D2020N**

Negative Ground

20A Max. Charge

20A Max. Load

**Advanced Solar Charge Controller**

## **DINGO User Guide**

Read this before installing

## **This is not an MPPT device:**

There is no voltage conversion.

Suitable array max power voltages are:

- 12 volt system 16-19V
- 24 volt system 32-38V
- 48 volt system 64-76V.

This user guide contains information to set up simple systems. For more complex systems see the appropriate reference manual.

Reference Manuals are available from

**[www.plasmatronics.com.au](http://www.plasmatronics.com.au)**

The Dingo firmware version is shown on the serial number label under the wiring cover.

For firmware version V41 or earlier please use

Reference Manual version 1.4

For firmware version V43 or later use Reference manual V1.5 or later

Wiring Instructions 6

Using the Menus 8

Choosing your Settings 10

Monitoring your System 12

### **Install your controller:**

- Vertically, where air can circulate around it
- In a dry environment out of direct sunlight
- Away from flammable gases or liquids
- Away from spiders, wasps or other insects which might make nests in it
- Do not use countersunk screws to mount

Fig. 1

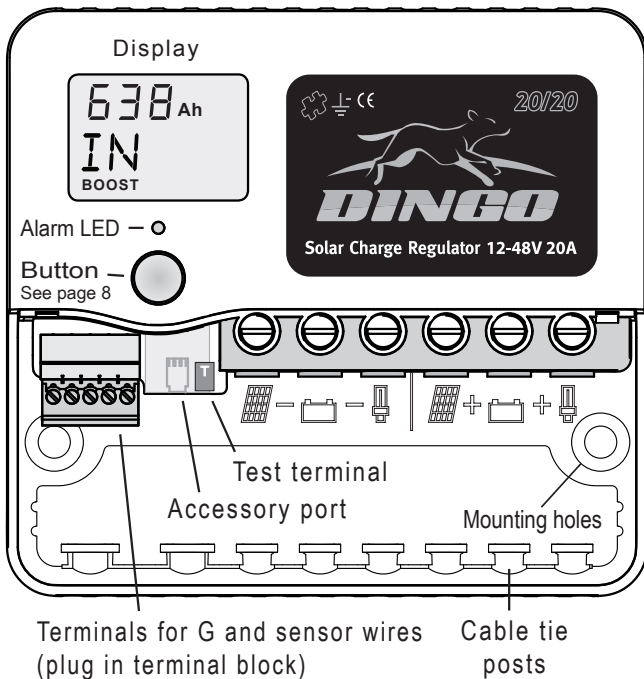

Screw wires into the high current terminals **tightly** in the order listed on page 6.

Warning: This controller is for DC current ONLY

Fig. 2

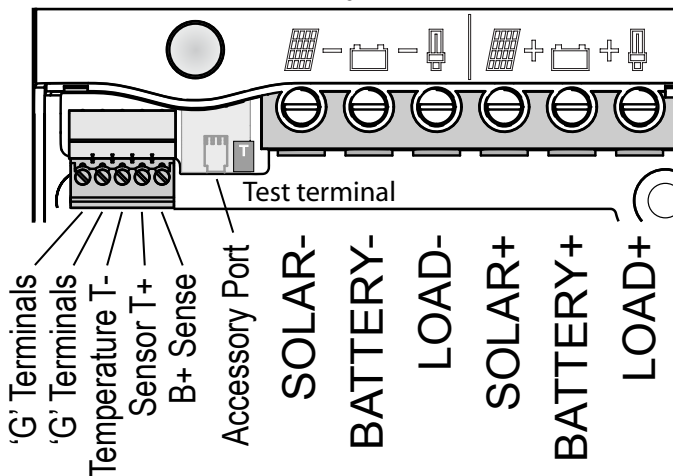

## Basic Connection Order

1. Connect Battery
2. Test Solar Polarity
3. Connect Solar
4. Connect Load

After connection you **must** set the system voltage (p10)

## Wiring instructions

For safety and to avoid damage, connection of wires must be done in the following order.

All connections must be tight!

- a. Connect the battery first. Positive to Battery +, Negative to Battery -. If the display comes on, the connection is correct. (see figure 3)
- b. Connect the negative (-) wire from the solar panel(s) to the solar panel negative (-) terminal.

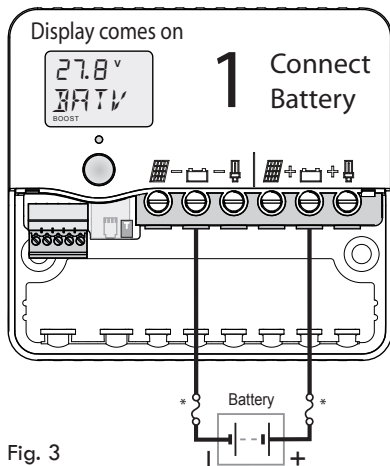

Fig. 3

### **WARNING:**

**The controller can be damaged quickly by reverse connection of the solar array in 32V, 36V and 48V systems. Test first to avoid damage.**

\*For safety, most installation standards require fuses or circuit breakers on both sides of the battery.

For other connections, see the reference manual.

**DO NOT CONNECT INVERTERS TO THE LOAD TERMINIAL**

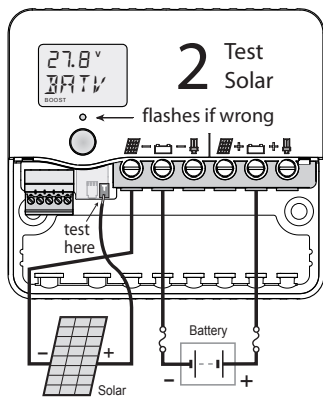
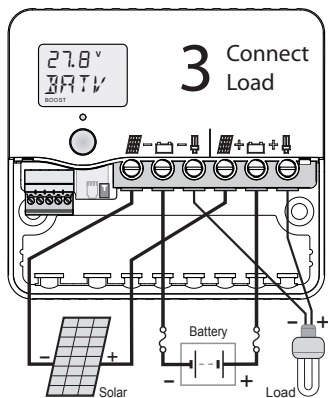

Fig. 4



- c. Test the solar panel connection by touching the positive (+) wire from the solar panel onto the Test terminal (T).
- If the alarm led does not flash then the polarity is correct.
  - If the alarm led flashes quickly the polarity is wrong. Check the polarity and test again. *(There must be some light on the solar panels for this test to work).* If correct, connect to the Solar positive (+) terminal.
- d. Connect the negative (-) wire from DC load circuit to the load negative (-) terminal and connect the positive wire from the load to the load positive (+) terminal. Test that the load circuit works. The controller is protected against load short circuits, but cannot protect your load devices if you reverse the connection to them. **Now, set the system voltage - see pg. 10**

*Note: The controller is protected against short circuits on the solar input.*

## Using the Menu System

You can move around the menu system and change settings using the button on the front of the controller. There are seven top-level menu items in the menu system (BATV, CHRG, LOAD etc - see figure 5). Each menu item provides access to a sub-menu, and some of these sub-menus lead again to further sub-menus.

A **short push** tells the controller to advance to the next menu item or setting value. To do a short push, press on the button on the front of the controller, and release it immediately.

A **long push** “selects”, moving into a sub-menu or allowing you to change settings. To do a long push, hold the button down until the menu changes (about one second).

### Getting back

Wherever you are in the menu system, a series of short-pushes will bring you back to the top-level menus without changing any settings. There are two exceptions: when a number is flashing during setting adjustment (see page 10) and when you see the word “EXIT” in the “HISTORY” sub menu - see page 16.

**Note:** *‘external’ screens do not appear if there are no accessories attached. If an accessory is attached, the screen names will indicate the accessory type.*



## Menu System (Programs 0-3 )

→ Thin arrow = short push

→ Thick arrow = long push

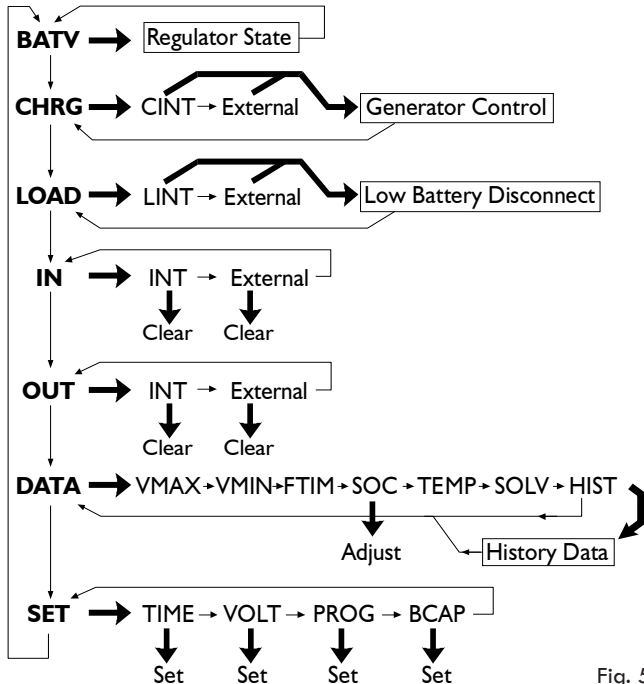

Fig. 5

## Choosing your settings

Failure to correctly set the system voltage (VOLT) and select the correct program (PROG) for your battery may result in damage to the battery or connected equipment. Follow this procedure:

### 1. Set the Time

- Short-push until the display shows “SET”.
- Long-push once and the display will show “TIME”.
- Long-push again, and the time will start flashing. (Note that the time is displayed in hours and tenths of hours. For example, “6.5” means 6:30am, and “13.1” means 1:06pm.)
- Short-push until the time shown is correct. If you reach 23.9 (11.54pm), it will cycle back to 0.0 (midnight).
- When the time shown is correct, long-push to set it.

*Note: time setting does not affect battery charging.*

### REVERSE & FAST FORWARD

If you overshoot the setting you want and need to go back, you can use reverse. Do a long push. The number stops flashing. Do another long push. The number starts flashing again but this time goes down. More than 5 quick pushes will start the fast forward mode. To return to normal mode, stop pushing for 1 second.

### 2. Set the System Voltage (! Important)

- Short-push to move from “TIME” to “VOLT”.
- Long-push and the voltage will start flashing.
- Short-push until the voltage is correct for your battery. If you pass 48V, it will cycle back to 12V.

d. When battery voltage is correct, long-push to set it.

### 3. Set your program (! Important)

The Dingo comes with a number of pre-set programs, to make configuration easy for most installations.

- Short-push to move from “VOLT” to “PROG”.
- Long-push and the program number will start flashing.
- Short-push to select the best program for your batteries:
- When the program shown is correct, long-push to set it.

#### Programs

- 0:** Liquid Electrolyte Battery with Low Battery Disconnect option (p.18)
- 1:** Sealed batteries (AGM or Gel) with Low Battery Disconnect option
- 2:** Liquid Electrolyte Battery with Light Controller option (see p.19)
- 3:** Sealed batteries (AGM or Gel) with Light Controller option.
- 4:** Customised setup. Choosing this program will require you to set a number of additional parameters. (see Reference Manual)

### 4. Set the Battery Capacity

Note: BCAP setting does not affect battery charging.

- Short-push to move from “PROG” to “BCAP”.
- Long-push and the battery capacity will start flashing.
- Short-push to choose the correct battery capacity for your system in Ampere hours (Ah). (Settings over 1000Ah display in thousands - e.g. 1600 Ah shows as “1.6”. Note: Look for the decimal point, eg 20=20Ah, 20.0=20,000Ah) If unsure, check your battery manual or consult your battery supplier.
- Long-push to keep the chosen value

## Monitoring your system

This controller's advanced monitoring functions provide you with unparalleled information about your system. Here are some questions that your controller can answer:

### **How much energy have I collected today?**

The top-level IN screen shows how many Amp hours have been collected today.

### **How much energy have I used today?**

The top-level OUT screen shows how many Amp hours the load has used today.

### **What voltage did the battery reach?**

VMAX shows today's maximum voltage since midnight; VMIN shows today's minimum voltage. Both are in the DATA sub-menu. (The battery voltage now is shown on the BATV screen.)

### **What is the charge current?**

The top level CHRG screen displays the charge current. This is the total current from all charge sources. The current which flows through the controller is called internal charge (CINT). In larger systems, there can be current which does not flow through the controller. This is called external charge (CEXT).

The CHRG screen displays the sum of the internal and external currents. By doing a long push on the CHRG screen you can see how much each device contributes to the total charge.

The first screen is called CINT and displays the internal charge. The next screen(s) display any currents reported by external devices. (For details, see the reference manual)

## **What is the load current?**

The top level LOAD screen displays the load (or discharge) current. This is the total current used by all loads. A long push will display the internal load current (LINT) and any external load currents.

## **How full is the battery?**

The voltage level of your battery is a good measure of how full it is, and is shown on the top-level “BATV” screen. Alternatively, SOC in the DATA sub-menu (long-push on DATA, then three short-pushes) uses amp-hour, voltage & temperature data to provide an estimate of the state of charge. (Warning: SOC will be meaningless if the controller is not measuring all the charge and discharge from the battery. For example, if an inverter is connected directly to the battery, an external shunt and an external shunt adaptor is needed so that the controller can include the inverter current in its calculations. There will also be errors due to temperature and the age of the battery).

## **What time did the battery finish charging today?**

The FTIM screen in the DATA sub-menu shows the time the controller finished charging and entered the “float” state (see page 17). If the controller did not change from absorption to float, then this will show as a dash (“-”).

For example, if the controller started the day in “float” mode and stayed there all day, the FTIM screen will show “-”.

## **Are components working correctly?**

A battery temperature sensor can be connected to your controller to improve regulation. If this sensor is installed, the battery temperature is shown on the TEMP screen in the DATA sub-menu. (If it is blank, no temperature sensor is attached).

To test your solar array, the SOLV screen in the DATA menu shows the open-circuit voltage of the solar array. (Note: charging is interrupted while the SOLV screen is displayed. If the controller is left in this state it will automatically turn the charge back on after a period of time. This is to prevent the controller being left in a non charging state)

## **How much heat can the Dingo take?**

The Dingo can operate at full charge and load current up to an ambient temperature of 50°C (122°F). Take care, the temperature inside a box will be higher than outside. For information on derating see appendix A4 of the Dingo Reference manual. The Dingo will also work down below -20°C (-4°F).

## The Data Menu

This is a quick summary of the screens in the data submenu which are reached by a long push on the DATA screen and the values stored each day by the history function.

- VMAX** Maximum battery voltage since midnight.
- VMIN** Minimum battery voltage since midnight.
- FTIM** Time of day the controller entered the Float state if it didn't begin in float (see page 17).
- SOC** Percentage estimate of the state of charge of the battery based on amp hours in/out. A very rough 'fuel gauge'.
- TEMP** Temperature being sensed by the battery temperature sensor (if attached).
- SOLV** Solar panel open circuit voltage.  
NB: charging stops while displaying this screen.
- HIST** Entry point for history data display. (See page 16)

At midnight, IN, OUT, VMAX, VMIN, FTIM and SOC are stored in the history data and reset. VMAX and VMIN respond very slowly to changes in battery voltage. This allows them to ignore short term voltage fluctuations.

## Retrieving historical data

In addition to storing today's performance data, the controller can display information about the last 99 days of operation. Historical performance information can be accessed from the DATA sub menu (see figure 6). After a long-push on DATA, short-push until you see HIST. A long-push on HIST will put you in "history mode", where you can cycle through each day's data. In the history display, DAY 1 is yesterday and DAY 99 is 99 days ago. (Note: the controller actually stores 512 days data, but this is only accessible via the computer interface)

### History Mode

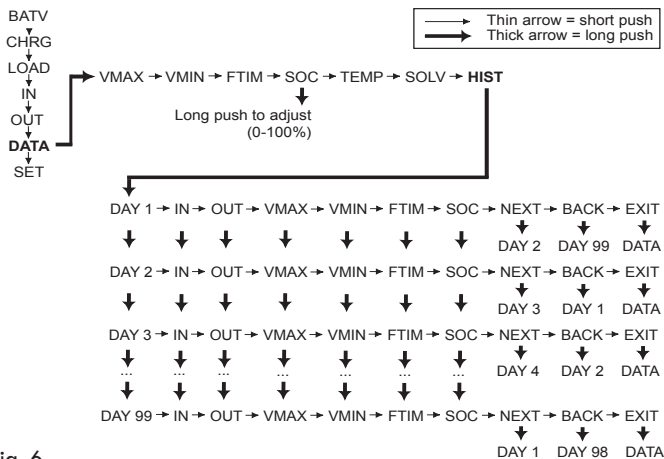

Fig. 6



## The Battery Charging Process

When charging your battery, the controller moves automatically through the following charging sequence:

**Boost phase** - In this phase, all available charge is used to charge the battery as quickly as possible. The “Boost” indicator appears on the controller’s screen.

**Absorption phase** - In this phase, the battery is nearly full. To avoid excess gassing, the charge current is adjusted to keep the battery at a lower, constant voltage.

**Float phase** - The battery is now fully charged. The controller maintains the battery at a lower voltage. If the battery voltage drops below a pre-set point, the controller will move back to the Boost phase automatically.

For flooded batteries, the controller will occasionally do a deliberate overcharge of the battery. This is called **Equalisation**. This phase helps level the charge between the different cells inside the battery by overcharging the battery for a short period. It will do this several times each year.

Figure 7 shows how the voltage of the battery varies during the charging process. The regulation settings shown in the diagram (BMAX, ETIM etc) can all be set individually in Program 4. This caters for the requirements of unusual installations.

For more information see the Reference Manual. The pre-set values provided by choosing Programs 0, 1, 2 or 3 will usually ensure good charge control without a complex setup process.

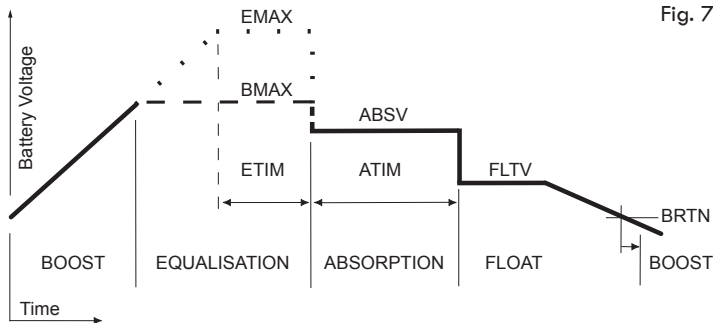

Fig. 7

A long push on BATV will show the regulator state. (BOST=Boost, EQUL=Equalise, ABSV=Absorption, or FLOT=Float). A long-push on that state will manually advance the Dingo into the next state. Or, to return to the BATV screen without changing the state, do a short push.

### Low Battery Disconnect (LBD)

To prevent battery damage due to overdischarge, the controller has an optional Low Battery Disconnect (LBD) function which can be set to turn off the load terminal if the battery falls below a pre-set voltage for a period of time.

Short-term battery voltage fluctuations caused by motors starting etc. will not activate LBD. Once the battery has recharged to a safe level, the load will automatically switch on again. This may take some time.

You do not have to use this feature, and the controller will still operate effectively without it.

To use Low Battery Disconnect, you need to connect your load to the regulator as described on page 7, and you should also ensure that you have chosen a program where the Low Battery Disconnect feature is activated - see page 11.

**Note - NEVER connect batteries or inverters to the load terminals of the controller.** They will cause heavy current flow which may damage the controller.

## Light Controller Option

There is a built in light controller which can switch lights on at night. When the voltage from the solar array drops, the Light Controller function will switch on power to the load terminals. If you have connected lights to the load terminals, they will switch on at dusk and switch off at dawn. *(The solar panel voltage is used to sense the light level.)*

If the battery voltage drops too low, the low battery disconnect function overrides the light controller and turns the lights off.

To use the Light Controller option, choose a program which enables this function, as described on page 11.

## Further information

This controller is capable of more than what is described in this user manual.

For information on how to customise your regulation setup and set up larger systems, as well as the many additional features, consult the Reference Manual. This can be downloaded from our website.

## Accessories

These accessories can enhance the usefulness of your controller.

### External Battery Temperature Sensor (DT or DTB)

The DT is a plastic-cased unit for direct attachment to the battery wall. The DTB has a bolt-on lug for attaching to the battery terminal (either terminal). It connects to the T+ and T- inputs on the green plug-in terminal block under the wiring cover. See Section 7.4.3 of the reference manual for details.

The following accessories plug into the serial port socket. (RJ11)

### External Shunt Adaptor (DSA)

Up to four external shunts can be added to the controller to allow it to measure larger currents than it is capable of measuring directly. The shunt adaptor measures the current in a shunt (eg SH200), converts it to digital information and sends that information to the controller. The shunt connection is isolated so the shunt can be placed in any part of the circuit. Currents up to +/-250A can be read in 0.1A steps.

## **Computer/Modem Serial Interface (DUSB, D232)**

A serial interface is available which allows the controller to communicate with a computer or be remote accessed via a modem. Both USB and RS232 versions are available. This is a quick way to load settings or extract performance data. All of the data is remotely accessible, and all settings can be adjusted. Windows based software is available to download the data. Data can then be loaded into a spreadsheet or other applications.

## **DNET**

The DNET Ethernet Gateway provides basic read-only access to the main parameters of the Dingo via HTTP, SNMP or Modbus TCP/IP

## **DRC**

The Dingo Remote Control allows all of the functions on the Dingo to be accessed remotely. Includes built-in audible alarm and display backlighting.

## **PUP**

The Dingo Pup operates as a charge controller or external switch, under the control of a Dingo.

## **Other accessories**

Check the website: [www.plasmatronics.com.au](http://www.plasmatronics.com.au)

## Settings Used in Programs 0-3

When programs 0-3 are selected, the controller automatically uses the values in the table on the right to control its operation.

The voltage settings are shown correct for 12V operation. For higher voltages, scale these up (eg. for a 24V system, multiply each voltage figure by 2.)

CHRG	Setting for program number			
	0	1	2	3
Parameter				
GMOD	0			
G ON (V)	11.5			
G OFF (V)	13.8			
GDEL (Min)	10			
GEXD (Day)	30			
GRUN (Hr)	1.0			

LOAD	Setting for program number			
	0	1	2	3
Parameter				
LOFF (V)	11.3			
L ON (V)	12.8			
LDEL (Min)	10			

SET/REG	Setting for program number			
	0	1	2	3
Parameter				
BMAX (V)	15.0	14.2	15.0	14.2
EMAX (V)	16.0	14.0	16.0	14.0
ETIM (Hr)	1.0	0	1.0	0
EFRQ (day)	45			
ABSV (V)	14.0			
ATIM (Hr)	2.0			
FLTV (V)	13.8			
HYST (V)	0.4			
BRTN (V)	12.3			
CHRG (A)	20			
BFRQ (Day)	15			
TCMP	0			

## Specifications

Nominal system voltages	12,24,32,36,48	V
Maximum voltage BAT+ to BAT-	100	V
Maximum short term voltage BAT+ to BAT- (2 minutes)	120	V
Maximum voltage SOL+ to BAT- (for a 48V system)	100	V
Maximum voltage LOAD+ to BAT+	70	V
Maximum voltage between the 'G' relay terminals	90	V
Maximum voltage B+ sense to BAT+	+/- 30	V
Maximum continuous charge current (SOL+)	20	A
Maximum continuous load current (LOAD+)	20	A
Maximum short term load current (5 minutes)	30	A
Maximum 'G' relay contact current	300	mA
Battery temperature sensor operating range	-20 to +70	°C
Maximum storage temperature	70	°C
Supply current (device only, battery at 12V)	<13	mA
Supply current (device only, battery at 60V)	<16	mA
Maximum supply current (with accessories)	27	mA
Meter accuracy	<+/-2% +/- 1 digit	
Maximum wire entry size (large terminals)	16mm <sup>2</sup> (6 AWG)	
Wire size, Green terminal block 0.2-1.3mm <sup>2</sup> (26 -16 AWG)		

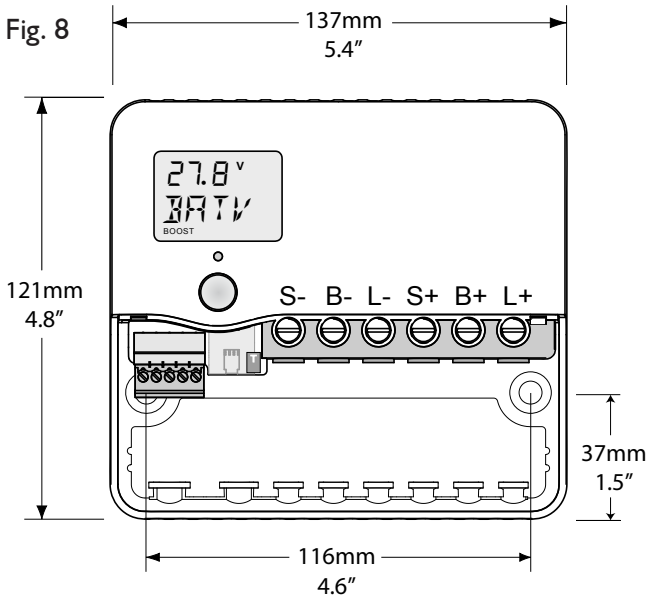

## Plasmatronics Pty Ltd

75 Newman St.

Thornbury 3071

Victoria, Australia

ph (61) 3 94869902

*info@plasmatronics.com.au*

*www.plasmatronics.com.au*