

DINGO 20/20 - INCREASING SOLAR CHARGING CAPACITY

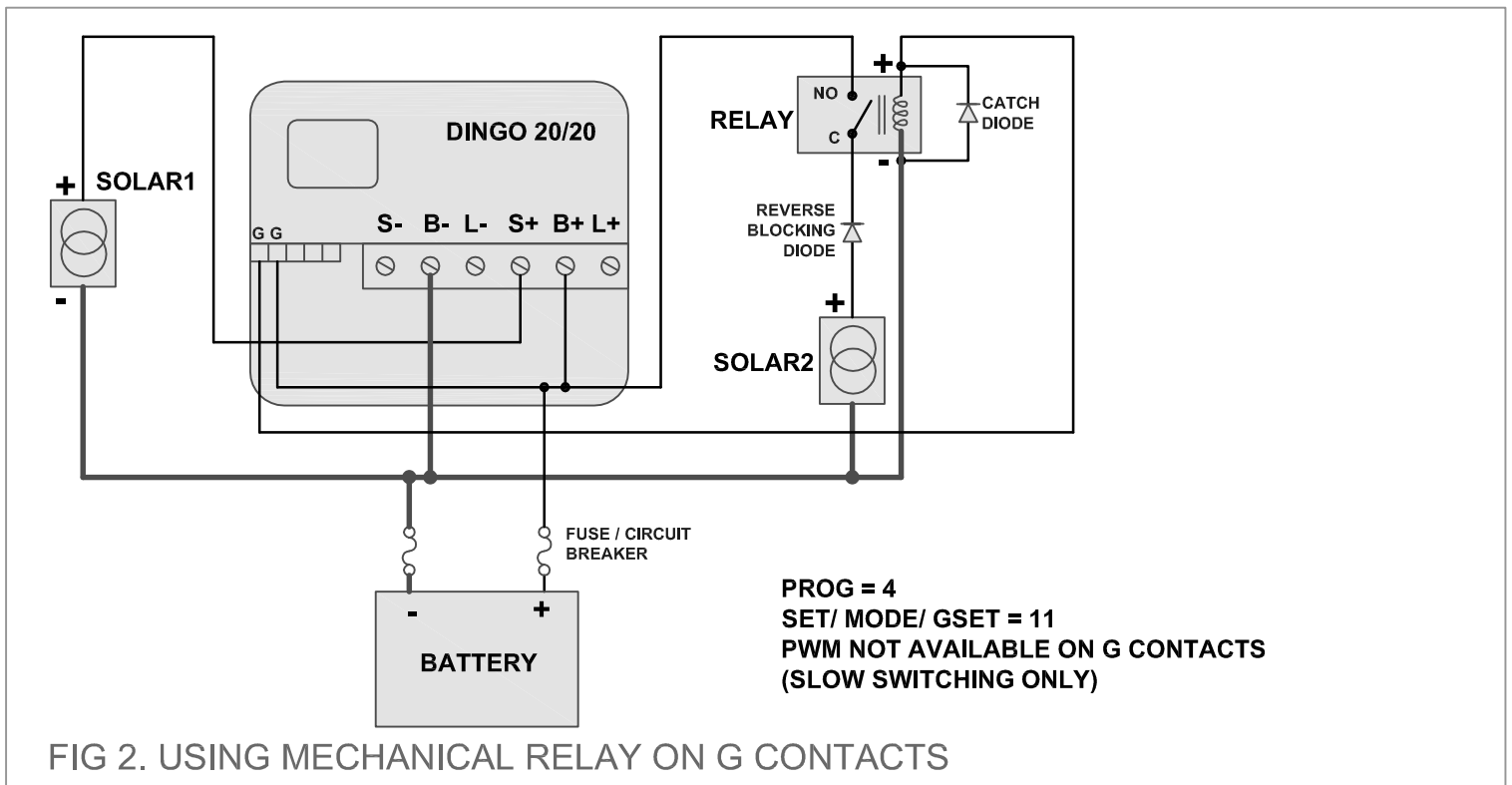
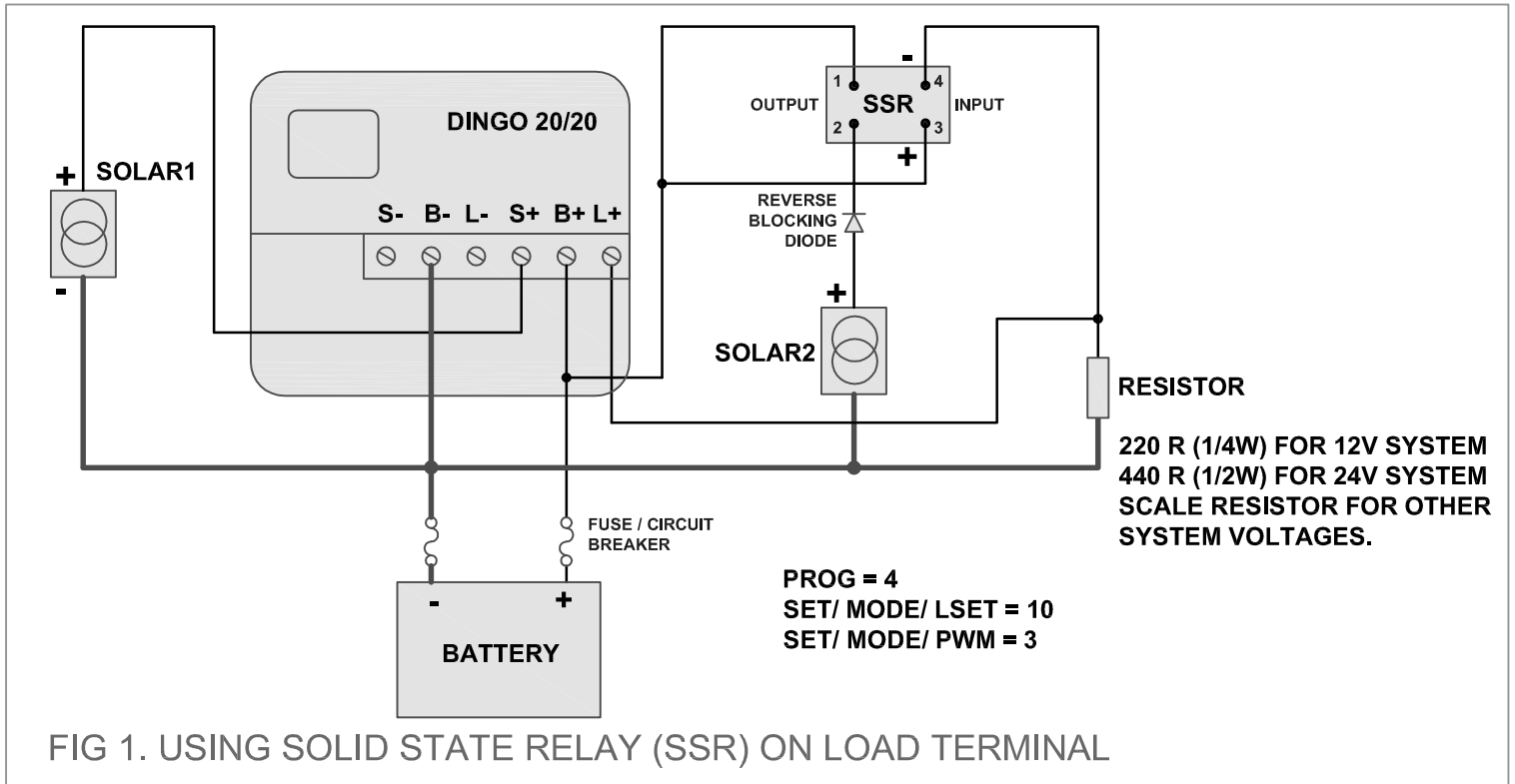

NOTES

1. THIS DIAGRAM IS FOR REFERENCE ONLY.
2. WIRING AND FUSES ETC. MUST BE INSTALLED AS SPECIFIED BY THE RELEVANT AUSTRALIAN STANDARDS.
3. THIS CONFIGURATION IS USED TO HANDLE CURRENTS HIGHER THAN THE 20A MAXIMUM AVAILABLE ON THE DINGO REGULATOR.
4. RELAY MUST BE RATED FOR THE MAXIMUM BATTERY VOLTAGE AND THE MAXIMUM CHARGING CURRENT AVAILABLE FROM SOLAR2.
5. IF USING A MECHANICAL RELAY, A CATCH DIODE SHOULD BE INSTALLED ACROSS THE COIL INPUT.
6. IN FIG 1, PWM = 3 ALLOWS PWM CONTROL ON BOTH THE SOLAR AND LOAD TERMINALS. IF A MECHANICAL RELAY IS USED IN PLACE OF THE SSR, PWM MUST BE SET TO 0 OR 1.
7. COMMONLY AVAILABLE SSR'S INCLUDE THE JG-33F 30V 100A SSR JAYCAR ELECTRONICS CAT NO. SY4086 WHICH IS SUITABLE FOR 12- 24V SYSTEMS. THERE IS ALSO THE CRYDOM D1D40 WHICH HAS A MUCH HIGHER VOLTAGE RANGE (100V 40A).
8. REVERSE BLOCKING DIODE SHOULD BE INSTALLED TO PREVENT BATTERY FROM DISCHARGING INTO SOLAR2 AT NIGHT.
9. FOR THE REGULATOR TO MEASURE THE SOLAR2 CHARGE CURRENT GOING THROUGH THE RELAY CONTACTS, A DINGO SHUNT ADAPTOR (DSA) AND SHUNT IS REQUIRED.